

# NIETZ

## AT20 series User Manual

Advanced Vector Control Inverter



NIETZ ELECTRIC CO.,LTD



- Thank you very much for your buying AT20 series High-performance Vector Control Inverter.
- Before use, please read this manual thoroughly to ensure proper usage. Keep this manual at an easily accessible place so that can refer anytime as necessary.

## Safety Precautions

Please read this operation manual carefully before installation, operation, maintenance or inspection. In this manual, the safety precautions were sorted to "WARNING" or "CAUTION".



### **WARNING**

Indicates a potentially dangerous situation which, if can not avoid will result in death or serious injury.



### **CAUTION**

Indicates a potentially dangerous situation which, if can not avoid will cause minor or moderate injury and damage the device. This Symbol is also used for warning any un-safety operation.

In some cases, even the contents of "CAUTION" still can cause serious accident. Please follow these important precautions in any situation.

In some cases, even the contents of "CAUTION" still can cause serious accident. Please follow these important precautions in any situation.

In some cases, even the contents of "CAUTION" still can cause serious accident. Please follow these important precautions in any situation.

★ NOTE indicate the necessary operation to ensure the device run properly.

Warning Marks are placed on the front cover of the inverter.

Please follow these indications when using the inverter.

<b>WARNING</b>
<ul style="list-style-type: none"> <li>● May cause injury or electric shock.</li> <li>● Please follow the instructions in the manual before installation or operation.</li> <li>● Disconnect all power line before opening front cover of unit. Wait at least 10 minutes until DC Bus capacitors discharge.</li> <li>● Use proper grounding techniques.</li> <li>● Never connect AC power to output UVW terminals.</li> </ul>

## Contents

<b>Chapter 1 Introduction</b> .....	<b>6</b>
1-1 Description of Name Plate .....	6
1-2 Technology Features .....	6
1-3 Installation .....	9
1-4 Selection Guide.....	12
1-5 Device recommended specifications.....	13
<b>Chapter 2 wiring</b> .....	<b>15</b>
2-1 Terminal Configuration .....	15
2-2 Wiring Diagram .....	16
<b>Chapter 3 Operation</b> .....	<b>21</b>
3-1 Keypad Description .....	21
<b>Chapter 4</b> .....	<b>24</b>
<b>Part of Detailed Function Description</b> .....	<b>24</b>
<b>Chapter 5</b> .....	<b>41</b>
<b>List of Function Parameters</b> .....	<b>41</b>

<b>Appdenix 1 .....</b>	<b>83</b>
<b>ParameterDescription of PID Control(0.4~2.2kW V/F) .....</b>	<b>83</b>
1. Main Functions of PID Control .....	83
2. Controlled parameters of PID .....	84
3.Fault alarm .....	88
<b>Appdenix 2 Parameter Description of PID Control Vector Control.....</b>	<b>90</b>
1. Controlled parameters of PID .....	90
2. Fault alarm .....	92
<b>Appdenix 3 Troubleshooting.....</b>	<b>93</b>
1 Fault alarm and countermeasures.....	93
2 Common Faults and Solutions .....	99
<b>Appendix 4 .....</b>	<b>102</b>
<b>Communication Protocol.....</b>	<b>102</b>
1, The agreement content .....	102
2, Application methods .....	102
3, Bus structure .....	102
4, Protocol Description .....	103
5, Communications data structure.....	103

# Chapter 1 Introduction

## 1-1 Description of Name Plate

**MODEL: AT20-03R7G4**

INPUT: 3PH 380V 50Hz/60Hz

OUTPUT: 3PH 380V 9.0

FREQ RANGE: 0.1-600Hz 3.7kW



14011311111

MODE: AT20- 03R7 G4

4: 3PH AC380V

2: 1PH AC220V

G/P: G:Costant torque

P:Variable torque

03R7:3.7kW

011:11kW

AT20 Series inverter

## 1-2 Technology Features

Item		AT20
Basic function	Control Mode	V/F control Sensorless flux vector control (SVC) Close-loop vector control (FVC)(Above 3.7KW)
	Maximum frequency	0~600Hz
	Carrier frequency	0.5kHz~8kHz The carrier frequency is automatically adjusted based on the load features.
	Input frequency resolution	Digital setting: 0.01Hz Analog setting: Maximum frequency x 0.025%
	Start torque	G Type: 0.5Hz/150%(SVC) P Type: 0.5Hz/100%
	Speed range	1: 100 (SVC)
	Speed stability accuracy	±0.5%(SVC)
	Overload capacity	G Type: 60s for 150% of the rated current, 3s for 180% of the rated current. P Type: 60s for 120% of the rated current, 3s for 150% of the rated current.

	Item	AT20
Basic function	Torque boost	Auto-boost; Customized boost: 0.1%~30.0%
	V/F Curve	Straight-line V/F curve Multi-point V/F curve N-power V/F curve (1.2-power, 1.4-power, 1.6-power, 1.8-power, square)
	V/F separation	2 types: complete separation; half separation
	Ramp Mode	Straight-line ramp. Four groups of acceleration/deceleration time with the range of 0.00~6500.0s
	DC braking	DC braking frequency: 0.00Hz~Maximum frequency Braking time: 0.0s~36.0s Braking action current value: 0.0%~100.0%
	JOG control	JOG frequency range: 0.00Hz~50.00Hz. JOG acceleration/deceleration time: 0.0s~6500.0s.
	Simple PLC, Multiple preset speeds	It implements up to 16 speeds via the simple PLC function or combination of terminal states
	Onboard PID	It realizes process-controlled closed loop control system easily
	Auto voltage regulation(AVR)	It can keep constant output voltage automatically when the mains voltage changes
	Overvoltage/overcurrent stall control	The current and voltage are limited automatically during the running process so as to avoid frequent tripping due to over voltage/over current
	Rapid current limit	It helps to avoid frequent over current faults of the AC drive.
	Torque limit and control	It can limit the torque automatically and prevent frequent over current tripping during the running process. Torque control can be implemented in the FVC mode.
Individualized functions	High performance	Control of asynchronous motor are implemented through the high-performance current vector control technology
	Rapid dip ride through	The load feedback energy compensates the voltage reduction so that the AC drive can continue to run for a short time
	Support for multiple PG card	Support for differential input PG card, resolver PG card, rotating transformer PG card...
	Rapid current limit	It helps to avoid frequent over current faults of the AC drive.
	Timing control	Timing range: 0.0Min~6500.0Min
	Communication methods	RS - 485

## Operation Instruction of AT20 Series Inverter

	Item	AT20
Running	Command source	Operation panel/Control terminals/Serial communication port You can perform switchover between these sources in various ways.
	Frequency source	There are ten frequency sources. Digital setting, analog voltage setting, analog current setting, pulse setting, serial port setting. You can perform switchover in various ways.
	Auxiliary frequency source	There are ten auxiliary frequency sources. It can implement fine tuning of auxiliary frequency and frequency synthesis.
	Input terminal	Standard: 4 digital input terminals(Below 5.5KW) /6 digital input terminals(Above 7.5KW); 1 analog input terminal(Below 5.5KW)/2 analog input terminals(Above 7.5KW); 1 voltage input (only support for 0~10V, above 7.5KW), 1 voltage input(0~10V) or current input (4~20mA)
	Output terminal	1 High-speed pulse output terminal (Open-collector) (Above 3.7KW) 1 replay output terminal (Below 5.5KW)/2 replay output terminals(Above 7.5KW) 1 analog output terminal(3.7KW~5.5KW)/2 analog output terminal(Above 7.5KW), Support for 4~20mA current output or 0~10V voltage output
Display and operation panel	LED display	It displays the parameters
	Key locking and function selection	It can lock the keys partially or completely and define the function range of some keys so as to prevent mal-function.
	Protection mode	Motor short-circuit detection at power-on, input/output phase loss protection, over current protection, over voltage protection, under voltage protection, overheat protection and overload protection
Environment	Installation location	Indoor, free from direct sunlight, dust, corrosive gas, combustible gas, oil smoke, vapor, drip or salt.
	Altitude	Lower than 1000m
	Ambient temperature	-10°C ~+ 40°C ( de-rated if the ambient temperature is between 40°C ~50°C )
	Humidity	Less than 95%RH, without condensing
	Vibration	Less than 5.9m/s <sup>2</sup> (0.6g)
	Storage temperature	-20°C ~+ 60°C



### 1-3 Installation

#### SIZE A

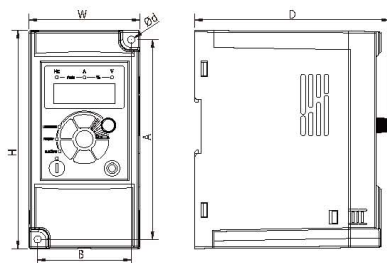

#### SIZE B

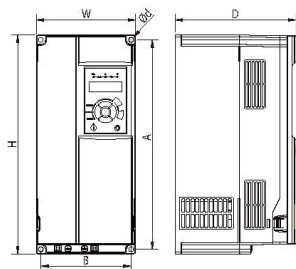

SIZE	Model	W	H	D	A	B	Φd
A	AT20-00R4G2 (V/F)	72	142	127	130	61	4.5
	AT20-00R7G2 (V/F)						
	AT20-01R5G2 (V/F)						
	AT20-02R2G2 (V/F)						
	AT20-00R7G4 (V/F)						
	AT20-01R5G4 (V/F)						
A	AT20-00R4G2	72	142	127	130	61	4.5
	AT20-00R7G2						
	AT20-01R5G2						
	AT20-00R7G4						
	AT20-01R5G4						
	AT20-02R2G4						

## Operation Instruction of AT20 Series Inverter

SIZE	Model	W	H	D	A	B	Φd
A	AT20-02R2G2 AT20-03R7G2 AT20-03R7G4 AT20-05R5G4	85	180	131	167	72	5.5
B	AT20-05R5G2 AT20-07R5G4 AT20-011G4	106	240	168	230	96	4.5
B	AT20-07R5G2 AT20-015G4 AT20-018.5G4 AT20-022G4	151	332	183	318	137	7
B	AT20-030G4 AT20-037G4	217	400	216	385	202	7

### SIZE C

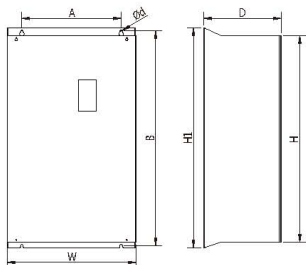

SIZE	Model	W	H	H1	D	A	B	Φd
C	AT20-045G4 AT20-055G4 AT20-075P4	300	440	470	240	200	455	9
C	AT20-075G4 AT20-090G4 AT20-110G4	275	590	630	310	200	612	9
C	AT20-132G4 AT20-160G4	400	675	715	310	320	695	11

## SIZE D

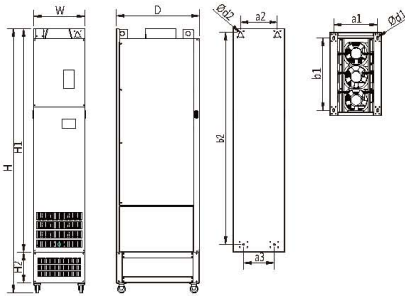

SIZE	Model	Outline dimension (mm)					Installation Size (mm)			Wall-mounted Size (mm)			
		W	H	H1	H2	D	a1	b1	d1	a2	a3	b2	d2
D	AT20-185G	300	1445	1180	200	500	250	430	14	220	150	1135	13
	AT20-200G												
	AT20-220G												
D	AT20-250G	330	1595	1330	200	545	280	475	14	220	185	1275	13
D	AT20-280G	325	1495	1230	200	545	275	470	14	225	185	1175	14
	AT20-315G												
D	AT20-350G	335	1720	1455	200	545	285	470	14	240	200	1380	14
	AT20-400G												
	AT20-450G												

**1-4 Selection Guide**

Model	Input voltage	Rated output power (kW)	Rated input current (A)	Rated output current (A)	Motor Power (KW)
AT20-00R4G2	AC220V±15% 1PH	0.4	5.4	2.5	0.4
AT20-00R7G2		0.75	7.2	5	0.75
AT20-01R5G2		1.5	10	7	1.5
AT20-02R2G2		2.2	16	11	2.2
AT20-03R7G2		3.7	17	16.5	3.7
AT20-00R7G4	AC380V±15% 3PH	0.75	3.8	2.5	0.75
AT20-01R5G4		1.5	5	3.7	1.5
AT20-02R2G4		2.2	5.8	5	2.2
AT20-03R7G4		3.7/5.5	10/15	9/13	3.7/5.5
AT20-05R5G4		5.5/7.5	15/20	13/17	5.5/7.5
AT20-07R5G4		7.5/11	20/26	17/25	7.5/11
AT20-011G4		11/15	26/35	25/32	11/15
AT20-015G4		15/18.5	35/38	32/37	15/18.5
AT20-018.5G4		18.5/22	38/46	37/45	18.5/22
AT20-022G4		22/30	46/62	45/60	22/30
AT20-030G4		30/37	62/76	60/75	30/37
AT20-037G4		37/45	76/90	75/90	37/45
AT20-045G4		45/55	92/113	90/110	45/55
AT20-055G4		55/75	113/157	110/150	55/75
AT20-075G4		75/90	157/180	150/176	75/90
AT20-090G4		90/110	180/214	176/210	90/110
AT20-110G4		110/132	214/256	210/253	110/132
AT20-132G4		132/160	256/307	253/300	132/160
AT20-160G4		160/185	307/355	300/340	160/185

Model	Input voltage	Rated output power (kW)	Rated input current (A)	Rated output current (A)	Motor Power (KW)
AT20-185G	AC380V/±15% 3PH	185/200	355/385	340/380	185/200
AT20-200G		200/220	385/430	380/420	200/220
AT20-220G		220/250	430/475	420/470	220/250
AT20-250G		250/280	475/525	470/520	250/280
AT20-280G		280/315	525/610	520/600	280/315
AT20-315G		315/350	610/665	600/640	315/350
AT20-350G		350/400	665/700	640/690	350/400
AT20-400G		400/450	700/800	690/790	400/450
AT20-450G		450/500	800/865	790/860	450/500

### 1-5 Device recommended specifications

Model	Input voltage	Motor Output (kW)	Main Circuit Cable Type (mm <sup>2</sup> )	Breaker Selection (A)	Input Side Magnetic contractor (A)
AT20-00R4G2	1PH 220V 50/60HZ	0.4	0.75	10	9
AT20-00R7G2		0.75	0.75	16	12
AT20-01R5G2		1.5	1.5	25	18
AT20-02R2G2		2.2	2.5	32	25
AT20-03R7G2		3.7	2.5	40	32
AT20-00R7G4	3PH 380V 50/60HZ	0.75	0.75	6	9
AT20-01R5G4		1.5	0.75	10	9
AT20-02R2G4		2.2	0.75	10	9
AT20-03R7G4		3.7/5.5	1.5	16	12
AT20-05R5G4		5.5/7.5	2.5	20	18
AT20-07R5G4		7.5/11	4	32	25
AT20-011G4		11/15	4	40	32

## Operation Instruction of AT20 Series Inverter

Model	Input voltage	Motor Output (kW)	Main Circuit Cable Type (mm <sup>2</sup> )	Breaker Selection (A)	Input Side Magnetic contractor (A)
AT20-015G4	3PH 380V 50/60HZ	15/18.5	6	50	38
AT20-018.5G4		18.5/22	10	80	65
AT20-022G4		22/30	10	80	65
AT20-030G4		30/37	16	100	65
AT20-037G4		37/45	25	100	80
AT20-045G4		45/55	35	160	95
AT20-055G4		55/75	50	160	115
AT20-075G4		75/90	70	250	150
AT20-090G4		90/110	95	250	170
AT20-110G4		110/132	120	400	205
AT20-132G4		132/160	150	400	245
AT20-160G4		160/185	185	400	300
AT20-185G		185/200	185	500	410
AT20-200G		200/220	185	500	410
AT20-220G		220/250	240	630	410
AT20-250G		250/280	240	630	475
AT20-280G		280/315	150*2	700	620
AT20-315G		315/350	185*2	800	620
AT20-350G		350/400	185*2	800	620
AT20-400G		400/450	240*2	1000	800
AT20-450G	450/500	240*2	1000	800	

## Chapter 2 wiring

### 2-1 Terminal Configuration

#### 1. 1PH/220V 0.4-2.2kW&3PH/380V 0.4-2.2kW (VF control)



RB RC S2 S1 REV FWD RS- RS+ FIC +10V GND

#### 2. 1PH/220V 0.4-3.7kW&3PH/380V 0.4-5.5kW (vector control)



RB RC FWD REV S1 S2 S3 24V MO1 FOV FIC 10V GND RS+ RS-GND

Note: S3 terminal only supports NPN function, while other FWD, REV, S1, S2 can support PNP and NPN function

#### 3. 220V/5.5-7.5kW&380V/7.5kW above

24V COM FWD REV S1 S2 S3 S4 COM MO1



10V GND FIC FIV GND FOC FOV GND RS+ RS- TA TC RA RB RC

#### 4. Air compressor special terminal



FIC GND S2 S1 GND MO1 GND RS+ RS- RB RC

## 2-2 Wiring Diagram

### 1. 1PH/220V 0.4-2.2kW&3PH/380V/0.4-2.2kW(V/F control)

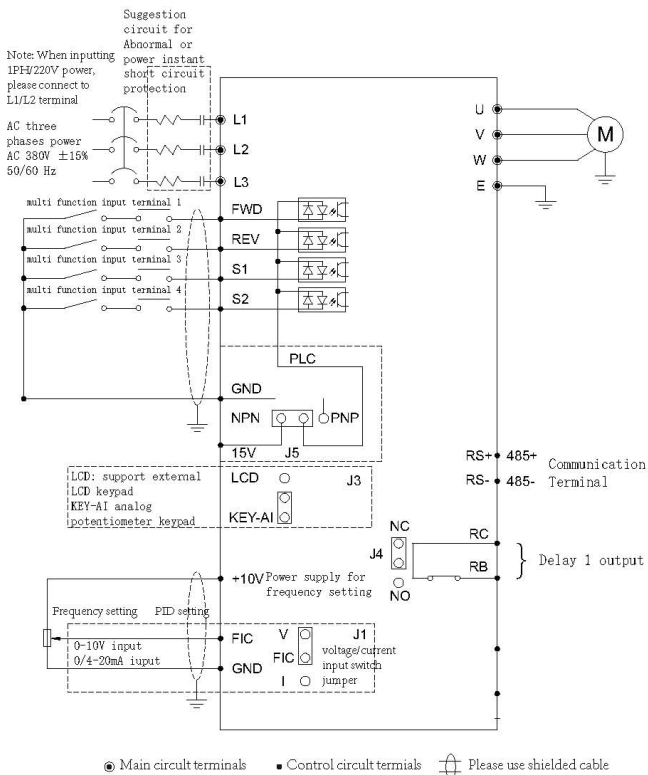



2. 1PH/220 0.4-1.5kW&3PH/380V 0.4-3.0kW (vector control)

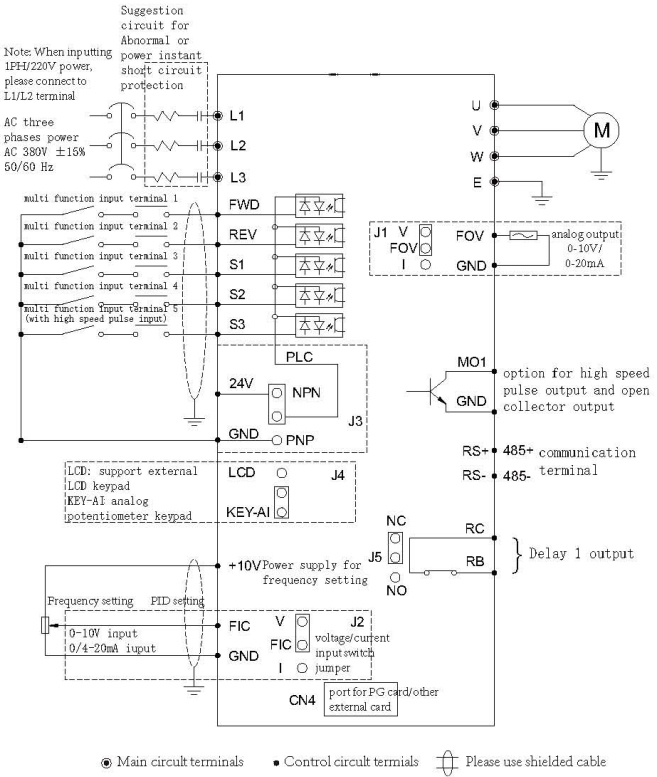

# Operation Instruction of AT20 Series Inverter

## 3. 1PH/220 2.2-3.7kW&3PH/380V 3.7-5.5kW (vector control)

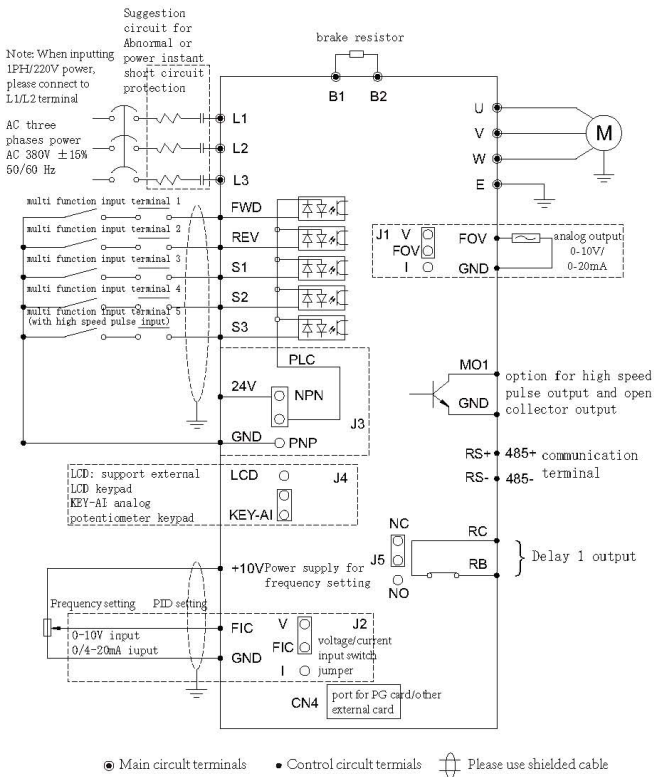

4. 220V/5.5-7.5kW&380V/7.5kW-160kW

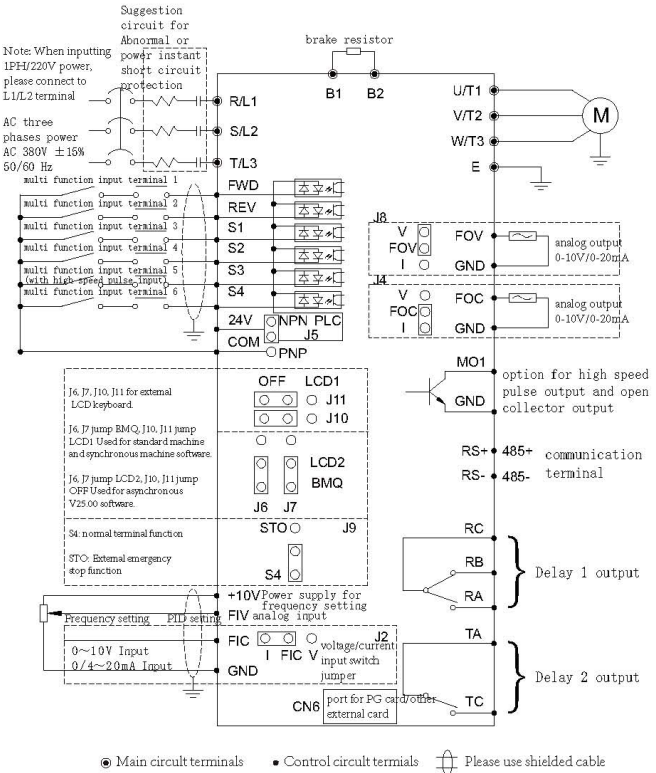

Note: 220V/ 5.5-7.5kw &380V/ 7.5-37kw standard built-in braking unit, 45kW-160kW braking unit optional.

# Operation Instruction of AT20 Series Inverter

## 5. 380V/185kW-450kW

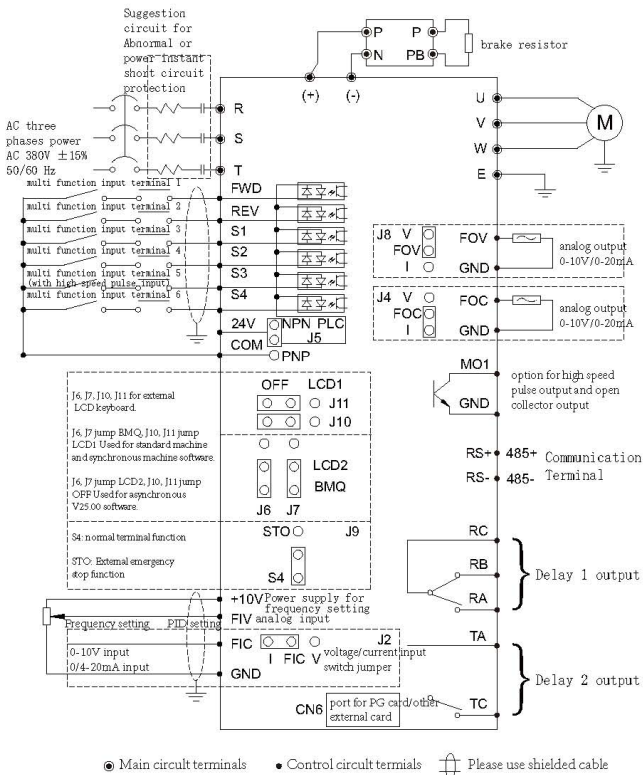

# Chapter 3 Operation

## 3-1 Keypad Description



### 1) 0.4KW-5.5KW

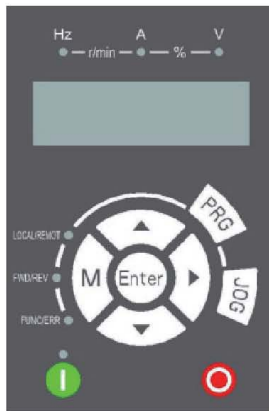

### 2) 7.5KW-450KW



## 3) Function key description

Key	Name	Description
PRG	Programming key	Entry or escape of first-level menu
ENTER	Data enter key	Progressively enter menu and confirm parameters
▲	UP Increment Key	Progressively increase data or function codes
▼	DOWN Decrement Key	Progressively decrease data or function codes
▶	Shift Key	In parameter setting mode, press this button to select the bit to be modified. In stop and running display modes, cyclically displays parameters by shift key.
	Run key	Start to run the inverter in keypad control mode
	Stop/Fault reset key	In running status, restricted by P7.02, can be used to stop the inverter. When fault alarm, can be used to reset the inverter without any restriction.
JOG	Shortcut Key	Determined by function code P7.01 0: No function 1: Switchover between operation panel command and remote operation command. It indicates the switchover between the current command source and operation panel control (local operation). If the current command source is operation panel control, the key is invalid. 2: Switch between forward and reverse, it only valid when command source is operation panel channel. 3: Forward JOG 4: Reverse JOG
M	No function	

## 4) Indicator light description

Indicator Light Name	Indicator light description
Hz	Frequency unit
A	Current unit
V	Voltage unit
FWD/REV	Extinguished: Forward operation Light on: Reverse operation

Indicator Light Name	Indicator light description
LOCAL/REMOT	Extinguished: Local operation Flickering: Terminal operation Light on: Communication control
FUNC/ERR	Extinguished: Running state Flickering: Pre-alarm of overload Light on: Fault
	Extinguished: Stop mode Flickering: In the process of auto-tuning Light on: Running mode

## Chapter 4

### Part of Detailed Function Description

P0.05	Auxiliary frequency source superposition Y range selection		Default	0
	Setting Range	0	Relative to the maximum frequency	
1		Relative to the main frequency source X		
P0.06	Auxiliary frequency source superposition Y range		Default	0
	Setting Range		0%~150%	

When selecting frequency source for the superposition of "frequency" (P0.03 set to 1, 3, or 4), these two parameters are used to determine the adjusting range of auxiliary frequency source.

P0.04 is used to determine the scope of the auxiliary frequency source of the object, the choice of relative to the maximum frequency, can also be relative to the rate of frequency source X, if choice is relative to the main frequency source, the scope of the secondary frequency source will change as the change of main frequency X.



P0.27	Binding command source to frequency source		Default	000
	Setting Range	Unit's digit	Binding operation panel command to frequency source	
		0	No binding	
		1	Frequency source by digital setting	
		2	FIV	
		3	FIC	
		4	Reserved	
		5	Pulse setting (S3)	
		6	Multi-reference	
		7	Simple PLC	
		8	PID	
	9	Communication setting		
	Ten's digit	Binding terminal command to frequency source(0~9, same as unit's digit)		
Hundred's digit	Binding communication command to frequency source(0~9, same as unit's digit)			

It is used to bind the three running command sources with the nine frequency sources, facilitating to implement synchronous switchover.

For details on the frequency sources, see the description of P0.03 (Main frequency source X selection). Different running command sources can be bound to the same frequency source.

If a command source has a bound frequency source, when the process of frequency source is effective, the command source set in P003 to P007 will no longer work.

P2.00	Speed loop proportional gain 1	Default	30
	Setting Range	1~100	
P2.01	Speed loop integral time 1	Default	0.50s
	Setting Range	0.01s~10.00s	
P2.02	Switchover frequency 1	Default	5.00Hz
	Setting Range	0.00~P3.05	
P2.03	Speed loop proportional gain 2	Default	20
	Setting Range	0~100	

P2.04	Speed loop integral time 2	Default	1.00s
	Setting Range	0.01s~10.00s	
P2.05	Switchover frequency 2	Default	10.00Hz
	Setting Range	P3.02~maximum output frequency	

Speed loop PI parameters vary with running frequencies of the AC drive.

If the running frequency is less than or equal to "Switchover frequency 1" (P2.02), the speed loop PI parameters are P2.00 and P2.01.

If the running frequency is equal to or greater than "Switchover frequency 2" (P2.05), the speed loop PI parameters are P2.03 and P2.04.

If the running frequency is between P2.02 and P2.05, the speed loop PI parameters are obtained from the linear switchover between the two groups of PI parameters, as shown in Figure 4-4.

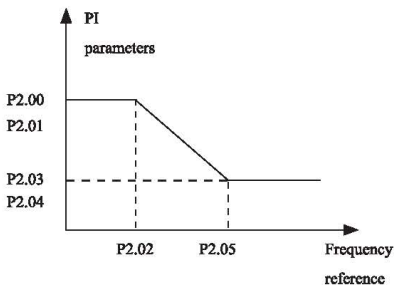

Figure 4-4 Relationship between running frequency and PI parameters

P2.11	Torque upper limit instruction in speed control mode (generation)		Default	0
	Setting Range	0	P2.10	
		1	Potentiometer on operation panel (below 5.5kW) FIV (above 7.5kW)	
		2	FIC	
		3	Reserved	
		4	Pulse setting (S3, above 3.7kW)	
		5	Communication setting	
		6	Min (Potentiometer on operation panel, FIC) (below 5.5kW) MIN (FIV,FIC) (above 7.5kW)	
		7	MAX (Potentiometer on operation panel, FIC) (below 5.5kW) MAX (FIV,FIC) (above 7.5kW)	
8	P2.12 setting full range of 1-7 corresponding to P2.12			
P2.12	Torque upper limit digital setting in speed control mode (generation)		Default	150.0%
	Setting Range		0.0%~200.0%	

In the speed control mode, if the AC drive is in the power generation state, it will output the maximum torque. P2.12 is used to control torque upper limit source in power generation.

P2.13	Excitation adjustment proportional gain	Default	2000
	Setting Range	0~20000	
P2.14	Excitation adjustment integral gain	Default	1300
	Setting Range	0~20000	
P2.15	Torque adjustment proportional gain	Default	2000
	Setting Range	0~20000	
P2.16	Torque adjustment integral gain	Default	1300
	Setting Range	0~20000	
P2.17	Speed loop integral property type	Default	0
	Setting Range	0 Invalid	
		1 Valid	

These are current loop PI parameters for vector control. These parameters are automatically

obtained through "Asynchronous motor complete auto-tuning ", and commonly need not be modified.

The dimension of the current loop integral regulator is integral gain rather than integral time.

Note that too large current loop PI gain may lead to oscillation of the entire control loop.

Therefore, when current oscillation or torque fluctuation is great, manually decrease the proportional gain or integral gain here.

P2.22	Generation power limit enabled	Default	0
	Setting Range	0	Disabled
		1	Enabled always
		2	Enabled when constant speed
		3	Enabled when deceleration
P2.23	Generation power upper limit	Default	Model dependent
	Setting Range	0.0%~200.0%	

In the speed control mode, if the AC drive is in the power generation state, it can select generation power limit mode to limit the generation power.

P3.09	V/F slip compensation gain	Default	0.0%
	Setting Range	0%~200.0%	

V/F slip compensation parameter is valid only for the asynchronous motor.

It can compensate the rotational speed slip of the asynchronous motor when the load of the motor increases, stabilizing the motor speed in case load changes.

If this parameter is set to 100%, it indicates that the compensation when the motor bears rated load is the rated motor slip. The rated motor slip is automatically obtained by the AC drive through calculation based on the rated motor frequency and rated motor rotational speed in group F1.

When adjust the V/F slip compensation gain, Generally, At rated load, if the motor rotational speed is different from the target speed, slightly adjust this Parameter.

P3.10	V/F over-excitation gain	Default	64
	Setting Range	0~200	

During deceleration of the AC drive, over-excitation can restrain rise of the bus voltage, to prevent the over-voltage fault. The larger the over-excitation is, the better the restraining result is.

Increase the over-excitation gain if the AC drive is liable to over-voltage error during deceleration. However, too large over-excitation gain may lead to an increase in the output current. Set P4.09 to a proper value in actual applications.

Set the over-excitation gain to 0 in the applications where the inertia is small and the bus voltage will not rise during motor deceleration or where there is a braking resistor.

P3.11	V/F oscillation suppression gain	Default	Model dependent
	Setting Range	0~100	

Set this parameter to a value as small as possible in the prerequisite of efficient oscillation suppression to avoid influence on V/F control. Set this parameter to 0 if the motor has no oscillation. Increase the value properly only when the motor has obvious oscillation. The larger the value is, the more obvious the oscillation suppression result will be.

When the oscillation suppression function is enabled, the rated motor current and no-load current must be correct. Otherwise, the V/F oscillation suppression effect will not be satisfactory.

P3.18	Action current of the over current lost speed	Default	150%
	Setting Range	50%~200%	
P3.19	Over current lost speed enabled	Default	1
	Setting Range	0 1	Disabled Enabled
P3.20	Over current lost speed suppression gain	Default	20
	Setting range	0~100	
P3.21	Triple-speed suppression of action current compensation coefficient	Default	50%
	Setting range	50%~200%	

In the high-frequency region, the motor running current is small.

Compared to the rated frequency, the speed of the motor drops greatly at the same stall current.

In order to improve the operating characteristics of the motor, you can reduce the stalling operating current that above the rated frequency. It is good effect to acceleration performance in some application require weaker magnetism and larger load, such as centrifuges that running frequency is higher.

Action current of the over current 150% means 1.5 times of the rated current of the inverter;

For high-power motors, the carrier frequency is below 2kHz. Due to the increase of pulsating current, the wave-by-wave current limiting response precedes the overcurrent stall prevention, and torque is insufficient, in this case, reduce the overcurrent stall to prevent operation current.

P3.22	Action voltage of the over voltage lost speed	Default	770.0V
	Setting Range	650.0V~800.0V	
P3.23	Over voltage lost speed enabled	Default	1
	Setting Range	0	Disabled
		1	Enabled
P3.24	Suppression frequency gain of over voltage lost speed	Default	30
	Setting range	0~100	
P3.25	Suppression voltage gain of over voltage lost speed	Default	30
	Setting range	0~100	
P3.26	Maximum rising frequency limit of over voltage lost speed	Default	5Hz
	Setting range	0~50Hz	

If the bus voltage exceeds the overvoltage stall point of 760V, it means that the electromechanical system is already in the power generation state (motor speed > output frequency), over-voltage stall will work, adjust the output frequency (consuming more electricity than feedback), the actual deceleration time will be automatically extended to avoid trip protection, if the actual deceleration time cannot meet the requirements, the overexcitation gain can be

appropriately increased.

When using a braking resistor or installing a braking unit or using an energy feedback unit, please note:

Please set P3.11 to "0". If it is not "0", it may cause excessive current during operation.

Please set P3.23 to "0". If it is not "0", it may cause the problem of extend deceleration time.

	Acceleration/ Deceleration mode	Default	0
P6.07	Setting Range	0	Linear acceleration/deceleration
		1	S-curve acceleration/deceleration A
		2	S-curve acceleration/deceleration B

It is used to set the frequency change mode during the AC drive start and stop process.

**0: Linear acceleration/deceleration**

The output frequency increases or decreases in linear mode. The AT20 provides four group of acceleration/deceleration time, which can be selected by using P4.00 to P4.08.

**1: S-curve acceleration/deceleration A**

The output frequency is increasing or decreasing as S-curve. S-curve is required to use in the occasion where smoothly start or stop, such as the elevator, conveyer belt, etc. Function code P6.08 and P6.09 respectively defines S-curve the start and end of the acceleration/deceleration time rate.

**2: S-curve acceleration/deceleration B**

In this curve, the rated motor frequency is always the inflexion point. This mode is fb usually used in applications where acceleration/deceleration is required at the speed higher than the rated frequency.

When the set frequency is higher than the rated frequency, the acceleration/deceleration time is:

$$t = \left( \frac{4}{9} * \left( \frac{f}{f_b} \right) + \frac{5}{9} \right) * T$$

In the formula, "f" is the set frequency, "fb" is the rated motor frequency and T is the acceleration time from 0 Hz to the rated frequency fb.

S-curve acceleration/deceleration B

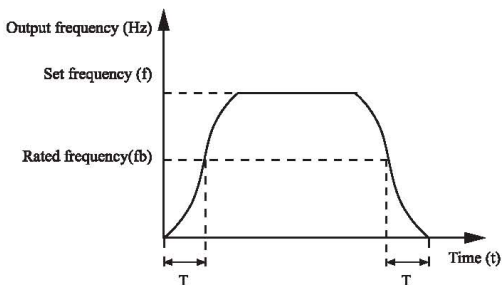

Figure 4-1 S-curve acceleration/deceleration B

P6.08	S-curve of beginning segment time proportional	Default	30.0%
	Setting Range	0.0%~(100.0%-P1.09)	
P6.09	S-curve of end segment time proportional	Default	30.0%
	Setting Range	0.0%~(100.0%-P1.08)	

These two parameters respectively define the time proportions of the start segment and the end segment of S-curve acceleration/deceleration A. They must satisfy the requirement:

$$P1.08 + P1.09 \leq 100.0\%$$

In Figure 4-1, t1 is the time defined in P4.08, within which the slope of the output frequency change increases gradually. t2 is the time defined in P4.09, within which the slope of the output frequency change gradually decreases to 0. Within the time between t1 and t2, the slope of the output frequency change remains unchanged, that is, linear acceleration/deceleration.



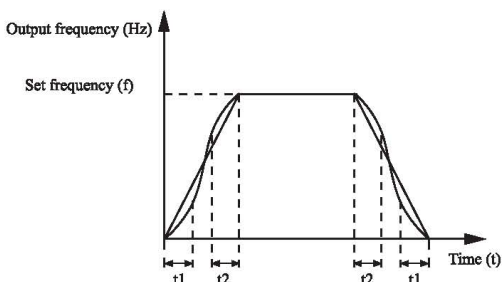

P6.15	Brake use rate	Default	100%
	Setting Range	0%~100%	

It is valid only for the AC drive with internal braking unit and used to adjust the duty ratio of the braking unit. The larger the value of this parameter is, the better the braking result will be. However, too larger value causes great fluctuation of the AC drive bus voltage during the braking process.

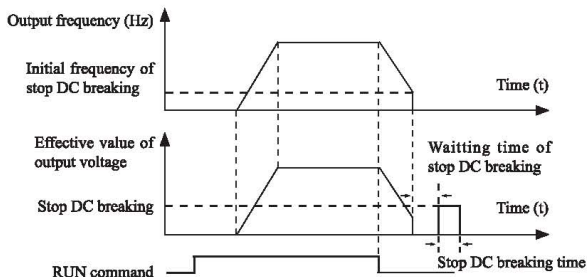

P6.25	Vector control over-excitation gain	Default	1.25
	Setting Range	1.00~2.50	

During deceleration of the AC drive, over-excitation control can restrain rise of the bus voltage to avoid the over-voltage fault. The larger the over-excitation gain is, the better the restraining effect is. Increase the over-excitation gain if the AC drive is liable to over-voltage error during deceleration. Too large over-excitation gain,

however, may lead to an increase in output current. Therefore, set this parameter to a proper value in actual applications.

Set the over-excitation gain to 0 in applications of small inertia ,the bus voltage will not rise during deceleration,or set the over-excitation gain to 0 where there is a braking resistor.

P7.06	Load speed display coefficient	Default	1.0000
	Setting Range	0.0001~6.5000	

This parameter is used to adjust the relationship between the output frequency of the AC drive and the load speed. For details, see the description of P7.12.

P7.07	Heatsink temperature of inverter module	Default	Read-only
	Setting Range	0.0°C~120.0°C	

It is used to display the insulated gate bipolar transistor (IGBT) temperature of the inverter module, and the IGBT overheat protection value of the inverter module depends on the model.

P8.14	Running mode when set frequency lower than frequency lower limit	Default	0
	Setting Range	0	Run at frequency lower limit
		1	Stop
	2	Run at zero speed	

It is used to set the AC drive running mode when the set frequency is lower than the frequency lower limit. The z2000 provides three running modes to satisfy requirements of various applications.

P8.15	Droop control	Default	0.00Hz
	Setting Range	0.00Hz~10.00Hz	

This function is used for balancing the workload allocation when multiple motors are used to drive the same load. The output frequency of the AC drives decreases as the load increases. You can reduce the workload of the motor under load by decreasing the output frequency for this motor, implementing workload balancing between multiple motors.

P8.16	Accumulative power-on time threshold	Default	0h
	Setting Range	0h~65000h	

If the accumulative power-on time (P7.13) reaches the value set in P8.16 , the corresponding M01 terminal outputs ON(P5.01=24).

P8.17	Accumulative running time threshold	Default	0h
	Setting Range	0h~65000h	

It is used to set the accumulative running time threshold of the AC drive. If the accumulative running time (P7.09) reaches the value set in this parameter, the corresponding M01 terminal outputs ON(P5.01=40).

P8.25	Frequency switchover point between acceleration time 1 and acceleration time 2	Default	0.00Hz
	Setting Range	0.00Hz~maximum frequency	
P8.26	Frequency switchover point between deceleration time 1 and deceleration time 2	Default	0.00Hz
	Setting Range	0.00Hz~maximum frequency	

This function is valid when the motor selects acceleration/ deceleration time that is not performed by means of X terminal's switchover. It is used to select different groups of acceleration/ deceleration time based on the running frequency range rather than X terminal during the running process of the AC drive.

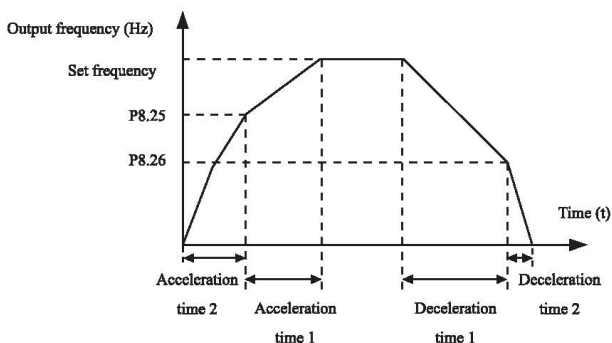

During the process of acceleration, if the running frequency is smaller than the value of P8.25, acceleration time 2 is selected. If the running frequency is larger than the value of P8.25, acceleration time 1 is selected.

During the process of deceleration, if the running frequency is larger than the value of P8.26, deceleration time 1 is selected. If the running frequency is smaller than the value of P8.26, deceleration time 2 is selected.

P8.30	Any frequency reaching detection value 1	Default	50.00Hz
	Setting Range	0.00 Hz ~ maximum frequency	
P8.31	Any frequency reaching detection amplitude 1	Default	0.0%
	Setting Range	0.0%~100.0%(maximum frequency)	
P8.32	Any frequency reaching detection value 2	Default	50.00Hz
	Setting Range	0.00Hz~maximum frequency	
P8.33	Any frequency reaching detection amplitude 2	Default	0.0%
	Setting Range	0.0%~100.0%(maximum frequency)	

If the output frequency of the AC drive is within the positive and negative amplitudes of the any frequency reaching detection value, the corresponding M01 outputs ON(P5.01=26/27)

The AT20 provides two groups of any frequency reaching detection parameters, including frequency detection value and detection amplitude, as shown in the following figure.

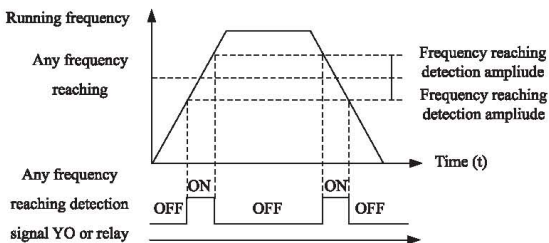

Figure 4-18 Any frequency reaching detection

P8.34	Zero current detection level	Default	5.0%
	Setting Range	0.0%~300.0%(rated motor current)	
P8.35	Zero current detection delay time	Default	0.10s
	Setting Range	0.00s~600.00s	

If the output current of the AC drive is equal to or less than the

zero current detection level and the duration exceeds the zero current detection delay time, the corresponding M01 becomes ON. The zero current detection is shown in the following figure.

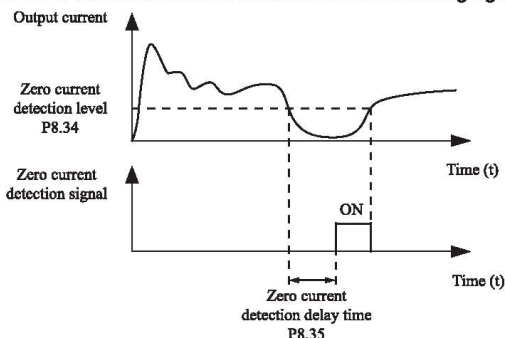

Figure 4-19 Zero current detection

P8.54	Output power correction coefficient	Default	100.0
	Setting Range	0	0.0~200.0

Can correct output power by modifying parameter P8.54, (output power can be viewed through the parameter D0.05)

P9.01	Motor overload protection gain	Default	1.00
	Setting Range	0.20~10.0	

When the motor running current reaches 150% of the rated motor current, and after continuous running for 1 minute, the motor will alarm overload.

When motor running current reaches 115% of the rated motor current, and after continuous running for 80 minutes, the motor will alarm overload.

For example: rated motor current 100A

If P9.01 set as 1.00, if motor running current reaches 125% of 100A(125A), continuous running for 40 minutes, the inverter alarm motor overload.

If P9.01 set as 1.20, if motor running current reaches 125% of 100A(125A), continuous running for  $40 \times 1.2 = 48$  minutes, the inverter alarm motor overload.

P9.07	Short-circuit to ground upon power on		Default	1
	Setting Range	0	Disabled	
		1	Enabled	

It can detect whether the motor is short-circuited to ground or not when the inverter power on, If this function is enabled, the UVW terminal of inverter will output voltage for some time after power-on.

P9.14	1st fault type	0~99
P9.15	2nd fault type	
P9.16	3rd (latest) fault type	

It is used to record the types of the recent three faults of the AC drive. 0 indicates no fault. For possible causes and solution of each fault, refer to Chapter 5.

PA.01	PID digital setting	Default	50.0%
	Setting Range	0.0%~100.0%	

PA.00 is used to select the channel of target process PID setting. The PID setting is a relative value and ranges from 0.0% to 100.0%. The PID feedback is also a relative value. The purpose of PID control is to make the PID setting and PID feedback the same.

PA.02	PID feedback source		Default	0
	Setting Range	0	FIV	
		1	FIC	
		2	Reserved	
		3	FIV-FIC	
		4	PULSE setting(X5)	
		5	Communication setting	
		6	FIV+FIC	
		7	MAX( FIV , FIC )	
8	MIN ( FIV , FIC )			

This parameter is used to select the feedback signal channel of process PID.

The PID feedback is a relative value and ranges from 0.0% to 100.0%.

PA.07	Differential time Td1	Default	0.000s
	Setting Range	0.00~10.000	

It decides the regulating intensity of the PID regulator on the deviation change. The longer the differential time is, the larger the

regulating intensity is. Differential time is the time within which the feedback value change reaches 100.0%, and then the adjustment amplitude reaches the maximum frequency.

PA.10	PID differential limit	Default	0.10%
	Setting Range	0.00%~100.00%	

It is used to set the PID differential output range. In PID control, the differential operation may easily cause system oscillation. Thus, the PID differential regulation is restricted to a small range. PA.10 is used to set the range of PID differential output.

PA.13	PID output filter time	Default	0.00s
	Setting Range	0.00s~60.00s	

PA.13 is used to filter the PID output frequency, helping to weaken sudden change of the AC drive output frequency but slowing down the response of the process closed-loop system.

PC.51	Reference 0 source	Default	0	
	Setting Range	0	Set by PC.00	
		1	FIV	
		2	FIC	
		3	Reserved	
		4	PULSE setting	
		5	PID	
		6	Set by preset frequency (P0.10), modified via terminal UP/DOWN	

It determines the setting channel of reference 0. You can perform convenient switchover between the setting channels. When multi-reference or simple PLC is used as frequency source, the switchover between two frequency sources can be realized easily.

C5.00	PWM switchover frequency upper limit	Default	12.00Hz
	Setting Range	0.00Hz~15Hz	

This parameter is valid only for V/F control.

It is used to determine the wave modulation mode in V/F control of asynchronous motor.

If the frequency is lower than the value of this parameter, the waveform is 7-segment continuous modulation. If the frequency is higher than the value of this parameter, the waveform is 5-segment intermittent modulation.

The 7-segment continuous modulation causes more loss to

switches of the AC drive but smaller current ripple. The 5-segment intermittent modulation causes less loss to switches of the AC drive but larger current ripple. This may lead to motor running instability at high frequency. Do not modify this parameter generally.

For instability of V/F control, refer to parameter P4.11. For loss to AC drive and temperature rise, refer to parameter P0.17.

C5.01	PWM modulation		Default	0
	Setting Range	0	Asynchronous modulation	
		1	Synchronous modulation	

Only V/F control is effective.asynchronous modulation is used when the output frequency is high( over 100HZ),conducive to the quality of the output voltage

C5.02	Dead compensation way		Default	1
	Setting Range	0	No compensation	
		1	compensation mode 1	
		2	compensation mode 2	

It doesn't have to modify generally.

C5.03	Random PWM depth		Default	0
	Setting Range	0	Random PWM is invalid	
		1-10	PWM carrier frequency random depth	

Random PWM depth is set to improve the motor's noise,reduce electromagnetic interference

C5.04	Fast current limiting open		Default	1
	Setting Range	0	Not open	
		1	Open	

Opening fast current limiting can reduce overcurrent fault,make the inverter work normally. Opening fast current limiting for a long time ,can make the inverter overheat,Report a fault CBC.CBC represents fast current limiting fault and need to stop.

C5.06	Undervoltage setting		Default	100%
	Setting Range	60.0-140.0%		

Used to set the voltage of inverter's lack voltage fault LU,Different voltage levels of inverter's 100%,corresponding to different voltages, Respectively single-phase 220V or three-phase 220V: three-phase 380V:350;three-phase 690V:650V



## Chapter 5

# List of Function Parameters

If PP-00 is set to a non-zero number, parameter protection is enabled. You must enter the correct user password to enter the menu. To cancel the password protection function, enter with password and set PP-00 to 0.

Parameters menu the user customizes are not protected by password. Group P is the basic function parameters, Group D is to monitor the function parameters. The symbols in the function code table are described as follows:

"☆": The parameter can be modified when the AC drive is in either stop or running state.

"★": The parameter cannot be modified when the AC drive is in the running state.

"●": The parameter is the actually measured value and cannot be modified.

"\*\*": The parameter is factory parameter and can be set only by the manufacturer.

Standard Function Parameters:

Function code	Parameter Name	Setting range	Default	Property
<b>Group P0 Standard Function Parameters</b>				
P0.00	G/P type display	1: G type (Constant torque load) 2: P type (variable torque load e.g. fan and pump)	Model dependent	●
P0.01	Control mode selection	0: No PG (speed sensor) vector control 1: With PG (speed sensor) vector control 2: V/F control	2	★

## Operation Instruction of AT20 Series Inverter

Function code	Parameter Name	Setting range	Default	Property
P0.02	Command source selection	0: Operation panel control (LED off) 1: Terminal control (LED on) 2: Communication control (LED linking)	0	☆
P0.03	Main frequency source X selection	0: Digital setting (P0.08 preset frequency, can modify the UP/DOWN, power lost don't memory) 1: Digital setting (P0.08, preset frequency, can modify the UP/DOWN, power lost memory) 2: FIV (above 7.5KW) 3: FIC 4: Potentiometer on operation panel (below 5.5KW) 5: PULSE (S3, Above 3.7KW) 6: Multistage instruction 7: Simple PLC 8: PID 9: Communication setting	0	★
P0.04	Auxiliary frequency source Y selection	The same as P0.03 (frequency source X selection)	0	★
P0.05	Auxiliary frequency source superposition Y range selection	0: Relative to the maximum frequency 1: Relative to the main frequency source X	0	☆
P0.06	Auxiliary frequency source superposition Y range	0%~150%	100%	☆

## Chapter 5 List of Function Parameters

Function code	Parameter Name	Setting range	Default	Property
P0.07	Frequency source superposition selection	Unit's digit (Frequency source) 0: Main frequency source X 1: X and Y operation (operation relationship determined by ten's digit) 2: Switchover between X and Y 3: Switchover between X and "X and Y operation" 4: Switchover between Y and "X and Y operation" Ten's digit (X and Y operation) 0: X+Y 1: X-Y 2: Both the maximum 3: Both the minimum	00	☆
P0.08	Frequency preset	0.00Hz~maximum frequency (P0.10)	50.00Hz	☆
P0.09	Rotation direction	0: Same direction 1: Reverse direction	0	☆
P0.10	Maximum frequency	50.00Hz~600.00Hz	50.00Hz	★
P0.11	Upper limit frequency source	0: P0.12 setting 1: Potentiometer on operate panel (below 5.5KW) FIV (above 7.5KW) 2: FIC 3: Reserved 4: PULSE (S3, above 3.7KW) 5: Communication setting	0	★
P0.12	Upper limit frequency	Frequency lower limit P0.14~Maximum frequency P0.10	50.00Hz	☆
P0.13	Upper limit frequency offset	0.00Hz~Maximum frequency P0.10	0.00Hz	☆
P0.14	Frequency lower limit	0.00Hz~Upper limit frequency P0.12	0.00Hz	☆
P0.15	Carrier frequency	0.5kHz~16.0kHz	Model dependent	☆

## Operation Instruction of AT20 Series Inverter

Function code	Parameter Name	Setting range	Default	Property
P0.16	Carrier frequency adjustment with temperature	0: No 1: Yes	1	☆
P0.17	Acceleration time 1	0.00s~65000s	Model dependent	☆
P0.18	Deceleration time 1	0.00s~65000s	Model dependent	☆
P0.19	Acceleration/Deceleration time unit	0: 1s 1: 0.1s 2: 0.01s	1	★
P0.21	Frequency offset of auxiliary frequency source for X and Y operation	0.00Hz~Maximum frequency P0.10	0.00Hz	☆
P0.22	Frequency instruction resolution	2: 0.01Hz	2	★
P0.23	Retentive of digital setting frequency upon power	0: Not retentive 1: Retentive	1	☆
P0.25	Acceleration/Deceleration time base frequency	0: Maximum frequency (P0.10) 1: Set frequency 2: 100Hz	1	★
P0.26	Base frequency for UP/DOWN modification during running	0: Running frequency 1: Set frequency	0	★

## Chapter 5 List of Function Parameters

Function code	Parameter Name	Setting range	Default	Property
P0.27	Binding command source to frequency source	Unit's digit: Binding operation panel command to frequency source 0: No binding 1: Frequency source by digital setting 2: Potentiometer on operation panel (below 5.5KW) FIV (above 7.5KW) 3: FIC 4: Reserved 5: PULSE (S3, above 3.7KW) 6:Multi-Reference 7:Simple PLC 8:PID 9:Communication setting Ten's digit: Binding terminal command to frequency source Hundred's digit: Binding communication command to frequency source	0000	☆
<b>Group P1 Motor parameter</b>				
P1.00	Motor type selection	0: Common asynchronous motor 1: Variable frequency asynchronous motor	0	★
P1.01	Rated motor power	0.1kW~1000.0kW	Model dependent	★
P1.02	Rated motor voltage	1V~2000V	Model dependent	★
P1.03	Rated motor current	0.01A~655.35A (AC drive power <=55kW) 0.1A~6553.5A (AC drive power >55kW)	Model dependent	★
P1.04	Rated motor frequency	0.01Hz~maximum frequency	Model dependent	★
P1.05	Rated motor rotational speed	1rpm~65535rpm	Model dependent	★

## Operation Instruction of AT20 Series Inverter

Function code	Parameter Name	Setting range	Default	Property
P1.06	Stator resistance (asynchronous motor)	0.001Ω~65.535Ω (AC drive power ≤55kW) 0.0001Ω~6.5535Ω (AC drive power >55kW)	Tuned parameter	★
P1.07	Rotor resistance (asynchronous motor)	0.001Ω~65.535Ω (AC drive power ≤55kW) 0.0001Ω~6.5535Ω (AC drive power >55kW)	Tuned parameter	★
P1.08	Leakage inductive reactance (asynchronous motor)	0.01mH~655.35mH (AC drive power ≤55kW) 0.001mH~65.535mH (AC drive power >55kW)	Tuned parameter	★
P1.09	Mutual inductive reactance (asynchronous motor)	0.1mH~6553.5mH (AC drive power ≤55kW) 0.01mH~655.35mH (AC drive power >55kW)	Tuned parameter	★
P1.10	No-load current (synchronous motor)	0.01A~P1.03 (AC drive power ≤55kW) 0.1A~P1.03 (AC drive power >55kW)	Tuned parameter	★
P1.27	Encoder pulses per revolution	1~65535	1024	★
P1.28	Encoder type	0: ABZ incremental encoder 2: Resolver	0	★
P1.30	AB phase sequence of ABZ incremental encoder AB phase sequence	0: Forward 1: Reverse	0	★
P1.31	Encoder install angle	0.0~359.9°	0.0°	★
P1.34	Rotation pole logarithm	1~65535	1	★
P1.36	Speed feedback PG card break line detection time	0.0: No action 0.1s~10.0s	0.0	★
P1.37	Auto tuning selection	0: No operation 1: static auto-tuning 2: dynamic auto-tuning 3: complete static auto-tuning	0	★

## Chapter 5 List of Function Parameters

Function code	Parameter Name	Setting range	Default	Property
<b>P2 Motor vector control parameter</b>				
P2.00	Speed loop proportional gain 1	1~100	30	☆
P2.01	Speed loop integral time 1	0.01s~10.00s	0.50s	☆
P2.02	Switchover frequency 1	0.00~P2.05	5.00Hz	☆
P2.03	Speed loop proportional gain 2	1~100	20	☆
P2.04	Speed loop integral time 2	0.01s~10.00s	1.00s	☆
P2.05	Switchover frequency 2	P2.02~Maximum frequency	10.00Hz	☆
P2.06	Vector control slip gain	50%~200%	100%	☆
P2.07	Time constant of speed loop filter	0.000s~0.100s	0.015s	☆
P2.08	Vector control over-excitation gain	0~200	64	☆
P2.09	Torque upper limit source in speed control mode	0: P2.10 1: Potentiometer on operation panel (below 5.5KW) FIV (above 7.5KW) 2: FIC 3: Reserved 4: PULSE (S3, above 3.7KW) 5: Communication setting 6: MIN (Potentiometer on operation panel, FIC) (below 5.5KW) MIN (FIV,FIC) (above 7.5KW) 7: MAX (Potentiometer on operation panel, FIC) (below 5.5KW) MAX (FIV,FIC) (above 7.5KW) The full range of 1-7 is correspond to P2.10	0	☆

## Operation Instruction of AT20 Series Inverter

Function code	Parameter Name	Setting range	Default	Property
P2.10	Torque upper limit setting in speed control mode (electrical)	0.0%~200.0%	150.0%	☆
P2.11	Torque upper limit instruction selection in speed control mode (generation)	0: P2.10 1: Potentiometer on operation panel (below 5.5KW) FIV (above 7.5KW) 2: FIC 3: Reserved 4: PULSE (S3, above 3.7KW) 5: Communication setting 6: MIN (Potentiometer on operation panel, FIC) (below 5.5KW) MIN (FIV,FIC) (above7.5KW) 7: MAX (Potentiometer on operation panel, FIC) (below 5.5KW) MAX (FIV,FIC) (above 7.5KW) 8: P2.12 setting Full range of 1-7 corresponding to P2.12	0	☆
P2.12	Torque upper limit digital setting in speed control mode (generation)	0.0%~200.0%	150.0%	☆
P2.13	Excitation adjustment proportional gain	0~60000	2000	☆
P2.14	Excitation adjustment integral gain	0~60000	1300	☆
P2.15	Torque adjustment proportional gain	0~60000	2000	☆
P2.16	Torque adjustment integral gain	0~60000	1300	☆



## Chapter 5 List of Function Parameters

Function code	Parameter Name	Setting range	Default	Property
P2.17	Speed loop integral property	Unit's digit: integral separation 0: Disabled 1: Enabled	0	☆
P2.21	Maximum torque coefficient of field weakening	50%~200%	100%	☆
P2.22	Generation power limit enabled	0: Disabled 1: Enabled always 2: Enabled when constant speed 3: Enabled when deceleration	0	☆
P2.23	Generation power upper limit	0.0%~200.0%	Model dependent	☆
<b>Group P3 V/F control parameters</b>				
P3.00	VF curve setting	0: Linear V/F 1: Multi-point V/F 2: Square V/F 3: 1.2-power V/F 4: 1.4-power V/F 6: 1.6-power V/F 8: 1.8-power V/F 9: Reserved 10: VF complete separation 11: VF half separation	0	★
P3.01	Torque boost	0.0%: (fixed torque boost) 0.1%~30.0%	Model dependent	☆
P3.02	Cut-off frequency of torque boost	0.00Hz~Maximum frequency	50.00Hz	★
P3.03	Multi-point VF frequency 1	0.00Hz~P3.05	0.00Hz	★
P3.04	Multi-point voltage 1	0.0%~100.0%	0.0%	★
P3.05	Multi-point VF frequency 2	P3.03~P3.07	0.00Hz	★
P3.06	Multi-point voltage 2	0.0%~100.0%	0.0%	★
P3.07	Multi-point VF frequency 3	P3.05~rated motor frequency (P1.04)	0.00Hz	★
P3.08	Multi-point voltage 3	0.0%~100.0%	0.0%	★

## Operation Instruction of AT20 Series Inverter

Function code	Parameter Name	Setting range	Default	Property
P3.09	V/F slip compensation gain	0.0%~200.0%	0.0%	☆
P3.10	V/F over-excitation gain	0~200	64	☆
P3.11	V/F oscillation suppression gain	0~100	Model dependent	☆
P3.13	Voltage source for V/F separation	0: Digital setting (P3.14) 1: Potentiometer on operation panel (below 5.5KW) FIV (above 7.5KW) 2: FIC 3: Reserved 4: PULSE (S3, above 3.7KW) 5: Multi-reference 6: Simple PLC 7: PID 8: Communication setting Note: 100.0% corresponding to the rated motor voltage	0	☆
P3.14	Voltage digital setting for V/F separation	0V~rated motor voltage	0V	☆
P3.15	Voltage acceleration time for V/F separation	0.0s~1000.0s Note: it indicated the time for the voltage change from 0V to rated motor voltage	0.0s	☆
P3.16	Voltage deceleration time for V/F separation	0.0s~1000.0s Note: it indicated the time for the voltage change from the rated motor voltage to 0V	0.0s	☆
P3.17	Stop mode selection for V/F separation	0: Frequency/voltage independent decline to 0 1: After voltage decline to 0 then decline the frequency	0	☆
P3.18	Action current of the over current lost speed	50%~200%	150%	★

## Chapter 5 List of Function Parameters

Function code	Parameter Name	Setting range	Default	Property
P3.19	Over current lost speed enabled	0: Disabled 1: Enabled	1	★
P3.20	Over current lost speed suppression gain	0~100	20	☆
P3.21	Triple-speed suppression of action current compensation coefficient	50%~200%	50%	★
P3.22	Action voltage of the over voltage lost speed	650.0V~800.0V	770.0V	★
P3.23	Over voltage lost speed enabled	0: Disabled 1: Enabled	1	★
P3.24	Suppression frequency gain of over voltage lost speed	0~100	30	☆
P3.25	Suppression voltage gain of over voltage lost speed	0~100	30	☆
P3.26	Maximum rising frequency limit of over voltage lost speed	0~50Hz	5Hz	★
<b>Group P4 Input terminal</b>				
P4.00	FWD terminal function selection	0: No function 1: Forward RUN (FWD) 2: Reverse RUN (REV) 3: Three-line control 4: Forward JOG (JOGF) 5: Reverse JOG (JOGR) 6: Terminal UP 7: Terminal DOWN	1	★
P4.01	REV terminal function selection	8: Coast to stop 9: Fault reset (RESET) 10: Run pause 11: Normally open(NO) input of external fault 12: Multi-reference terminal 1 13: Multi-reference terminal 2	2	★

## Operation Instruction of AT20 Series Inverter

Function code	Parameter Name	Setting range	Default	Property
P4.02	S1 terminal function selection	14: Multi-reference terminal 3 15: Multi-reference terminal 4 16: Terminal 1 for acceleration/ deceleration time selection 17: Terminal 2 for acceleration/ deceleration time selection 18: Frequency source switchover 19: UP/DOWN setting clear	0	★
P4.03	S2 terminal function selection	(terminal, operation panel) 20: Command source switchover terminal 21: Acceleration/ Deceleration prohibited 22: PID pause 23: PLC status reset 24: Swing pause 25: Counter input 26: Counter reset 27: Length count input 28: Length reset	0	★
P4.04	S3 terminal function selection	29: Torque control prohibited 30: PULSE frequency input (Enabled only for S3, above 3.7KW) 31: Reserved 32: Immediate DC braking 33: Normally closed (NC) input of external fault 34: Frequency modification enabled 35: Reverse PID action direction 36: External stop terminal 1	0	★

Function code	Parameter Name	Setting range	Default	Property
P4.05	S4 terminal function selection	37: Command source switchover terminal 2 38: PID integral pause 39: Switchover between main frequency source X and preset frequency 40: Switchover between auxiliary frequency source Y and preset frequency	0	★
P4.06	Reserved	41~42: Reserved 43: PID parameter switchover 44~45: Reserved	0	★
P4.07	Reserved	46: Speed control /Torque control switchover 47: Emergency stop 48: External stop terminal 2 49: Deceleration DC braking 50: Clear the current running time 51-59:Reserved	0	★
P4.10	X filter time	0.000s~1.000s	0.010s	☆
P4.11	Terminal command mode	0: Two-line mode 1 1: Two-line mode 2 2: Three-line mode 1 3: Three-line mode 2	0	★
P4.12	Terminal UP/DOWN rate	0.001Hz/s~65.535Hz/s	1.00Hz/s	☆
P4.13	FI curve 1 minimum input	0.00V~P4.15	0.00V	☆
P4.14	Corresponding setting of FI curve 1 minimum input	-100.0%~+100.0%	0.0%	☆
P4.15	FI curve 1 maximum input	P4.13~+10.00V	10.00V	☆
P4.16	Corresponding setting of FI curve 1 maximum input	-100.0%~+100.0%	100.0%	☆
P4.17	FI curve 1 filter time	0.00s~10.00s	0.10s	☆

## Operation Instruction of AT20 Series Inverter

Function code	Parameter Name	Setting range	Default	Property
P4.18	FI curve 2 minimum input	0.00V~P4.20	0.00V	☆
P4.19	Corresponding setting of FI curve 2 minimum input	-100.0%~+100.0%	0.0%	☆
P4.20	FI curve 2 maximum input	P4.18~+10.00V	10.00V	☆
P4.21	Corresponding setting of FI curve 2 maximum input	-100.0%~+100.0%	100.0%	☆
P4.22	FI curve 2 filter time	0.00s~10.00s	0.10s	☆
P4.23	FI curve 3 minimum input	-10.00V~P4.25	-10.00V	☆
P4.24	Corresponding setting of FI curve 3 minimum input	-100.0%~+100.0%	-100.0%	☆
P4.25	FI curve 3 maximum input	P4.23~+10.00V	10.00V	☆
P4.26	Corresponding setting of FI curve 3 maximum input	-100.0%~+100.0%	100.0%	☆
P4.27	FI curve 3 filter time	0.00s~10.00s	0.10s	☆
P4.28	PULSE minimum input	0.00kHz~P4.30	0.00kHz	☆
P4.29	Corresponding setting of PULSE minimum input	-100.0%~100.0%	0.0%	☆
P4.30	PULSE maximum input	P4.28~100.00kHz	50.00kHz	☆
P4.31	Corresponding setting of PULSE maximum input	-100.0%~100.0%	100.0%	☆
P4.32	PULSE filter time	0.00s~10.00s	0.10s	☆

## Chapter 5 List of Function Parameters

Function code	Parameter Name	Setting range	Default	Property
P4.33	FI curve selection	Unit's digit: Potentiometer on operation panel /FIV curve selection 1: Curve 1 (2 points, See P4.13~P4.16) 2: Curve 2 (2 points, See P4.18~P4.21) 3: Curve 3 (2 points, See P4.23~P4.26) 4: Curve 4 (4 points, See C6.00~C6.07) 5: Curve 5 (4 points, See C6.08~C6.15) Ten's digit: FIC curve selection, Same as FIV Hundred's digit: Reserved	321	☆
P4.34	Setting selection for FI less than minimum input	Unit's digit: Potentiometer on operation panel/Setting for FIV less than minimum input 0: Corresponds to the minimum input settings 1:0.0% Ten's digit: Setting selection for FIC less than minimum input (same as FIV)	000	☆
P4.35	FWD delay time	0.0s~3600.0s	0.0s	★
P4.36	REV delay time	0.0s~3600.0s	0.0s	★
P4.37	S1 delay time	0.0s~3600.0s	0.0s	★
P4.38	S terminal valid mode selection 1	0: High level valid 1: Low level valid Unit's digit: FWD Ten's digit: REV Hundred's digit: S1 Thousand's digit: S2 Ten thousand's digit: S3	00000	★
P4.39	S terminal valid mode selection 2	0: High level valid 1: Low level valid Unit's digit: S4 Ten's digit: Reserved Hundred's digit: Reserved Thousand's digit: Reserved Ten thousand's digit: Reserved	00000	★

## Operation Instruction of AT20 Series Inverter

Function code	Parameter Name	Setting range	Default	Property
<b>Group P5 Output terminals</b>				
P5.00	MO1 terminal output mode selection	0: Pulse output (YOP) 1: Switch signal output (YOR)	0	☆
P5.01	YOR output function selection	0: No output 1: AC drive running 2: Fault output (fault stop) 3: Frequency-level detection FDT1 output 4: Frequency reached 5: Zero-speed running(no output at stop) 6: Motor overload pre-warning 7: AC drive overload pre-warning 8: Setting count value Reached 9: Designated count value reached	0	☆
P5.02	Relay function selection on control board (RA-RB-RC/RB-RC)	10: Length reached 11: PLC cycle complete 12: Accumulative running time reached 13: Frequency limited 14: Torque limited 15: Ready for RUN 16: FIV>FIC 17: Frequency upper limit reached 18: Frequency lower limit reached (Relate to running) 19: Under voltage state output	2	☆
P5.03	Relay function selection (TA-TC)	20: Communication setting 21: (Reserved) 22: (Reserved) 23: Zero-speed running 2 (having output at stop) 24: Accumulative power-on time reached 25: Frequency level detection FDT2 output 26: Frequency 1 reached output	0	☆



## Chapter 5 List of Function Parameters

Function code	Parameter Name	Setting range	Default	Property
P5.04	Reserved	27: Frequency 2 reached output 28: Current 1 reached output	1	☆
P5.05	Reserved	29: Current 2 reached output 30: Timing reached output 31: FIV input limit exceeded 32: Load becoming 0 33: Reverse running 34: Zero current state 35: Module temperature reached 36: Output current limit exceeded 37: Frequency lower limit reached (having output at stop) 38: Alarm output( Keep running) 40: Current running time reached 41: Fault	4	☆
P5.06	YOP output function selection	0: Running frequency 1: Setting frequency 2: Output current 3: Output torque 4: Output power 5: Output voltage	0	☆
P5.07	FOV output function selection (above 3.7KW)	6: PULSE input (100.% corresponding to 100.0kHz) 7: FIV 8: FIC 9: Reserved 10: Length 11: Count value 12: Communication setting 13: Motor rotational speed 14: Output current (100.0% corresponding to 1000.0A) 15: Output voltage (100.0% corresponding to 1000.0V)	0	☆

## Operation Instruction of AT20 Series Inverter

Function code	Parameter Name	Setting range	Default	Property
P5.08	FOC output function selection (above 7.5KW)	16: Motor output torque (Actual value, corresponding to the motor percentage)	1	☆
P5.09	YOP output maximum frequency	0.01kHz~100.00kHz	50.00kHz	☆
P5.10	FOV bias coefficient	-100.0%~+100.0%	0.0%	☆
P5.11	FOV gain	-10.00~+10.00	1.00	☆
P5.12	FOC bias coefficient	-100.0%~+100.0%	0.0%	☆
P5.13	FOC gain	-10.00~+10.00	1.00	☆
P5.17	YOR output delay time	0.0s~3600.0s	0.0s	☆
P5.18	RA-RB-RC/RB-RC output delay time	0.0s~3600.0s	0.0s	☆
P5.19	TA-TC output delay time	0.0s~3600.0s	0.0s	☆
P5.20	Reserved	0.0s~3600.0s	0.0s	☆
P5.21	Reserved	0.0s~3600.0s	0.0s	☆
P5.22	Output terminal valid mode selection	0: Positive logic 1: Negative logic Unit's digit: YOR Ten's digit: RA-RB-RC/RB-RC Hundred's digit: TA-TC Thousand's digit: FOV (Above 3.7KW) Ten thousand's digit: FOC (above 7.5KW)	00000	☆
<b>Group P6 Start/Stop parameter</b>				
P6.00	Start mode	0: Direct start 1: Rotational speed tracking restart Speed tracking restarts 2: Pre-excited start (AC asynchronous motor) 3: SVC quick start	0	☆

## Chapter 5 List of Function Parameters

Function code	Parameter Name	Setting range	Default	Property
P6.01	Rotational speed tracking mode	0: Start from the stop frequency 1: Start from 0 2: Start from maximum frequency	0	★
P6.02	Rotational speed tracking	1~100	20	☆
P6.03	Startup frequency	0.00Hz~10.00Hz	0.00Hz	☆
P6.04	Startup frequency holding time	0.0s~100.0s	0.0s	★
P6.05	Startup DC braking current/ Pre-excited current	0%~100%	50%	★
P6.06	Startup DC braking time/ Pre-excited time	0.0s~100.0s	0.0s	★
P6.07	Acceleration/ Deceleration mode	0: Straight-line acceleration/ deceleration 1: S curve acceleration/ deceleration A 2: Dynamic S curve acceleration/ deceleration	0	★
P6.08	S curve of beginning segment time proportional	0.0%~(100.0%-P6.09)	30.0%	★
P6.09	S curve of end segment time proportional	0.0%~(100.0%-P6.08)	30.0%	★
P6.10	Stop mode	0: Deceleration to stop 1: Coast to stop	0	☆
P6.11	Initial frequency of stop DC braking	0.00Hz~maximum frequency	0.00Hz	☆
P6.12	Waiting time of stop DC braking	0.0s~100.0s	0.0s	☆
P6.13	Stop DC braking current	0%~100%	0%	☆

## Operation Instruction of AT20 Series Inverter

Function code	Parameter Name	Setting range	Default	Property
P6.14	Stop DC braking time	0.0s~100.0s	0.0s	☆
P6.15	Brake use rate	0%~100%	100%	☆
P6.18	Rotational speed tracking current	30%~200%	Model dependent	★
P6.21	Demagnetization time (Valid for SVC)	0.00~5.00s	Model dependent	☆
P6.23	Over-excitation selection	0: Not effective 1: Effective only when deceleration 2: Effective always	0	☆
P6.24	Over-excitation suppression current value	0~150%	100%	☆
P6.25	Over-excitation gain	1.00~2.50	1.25	☆
<b>Group P7 Operation display and Display</b>				
P7.01	JOG function parameter	0: No function 1: Switchover between operation panel command and remote operation command. It indicates the switchover between the current command source and operation panel control (local operation). If the current command source is operation panel control, the key is invalid. 2: Switchover between forward and reverse through JOG, it only valid when command source is operation panel channel. 3: Forward Jog (JOG-FWD) 4: Reverse Jog (JOG-REV)	0	★

## Chapter 5 List of Function Parameters

Function code	Parameter Name	Setting range	Default	Property
P7.02	STOP/RESET key function	0: STOP/RESET key enabled only in operation panel control 1: STOP/RESET key enabled in any operation mode	1	☆
P7.03	LED display running parameter 1	0000~FFFF Bit00: Running frequency 1 (Hz) Bit01: Setting frequency (Hz) Bit02: Bus voltage (V) Bit03: Output voltage (V) Bit04: Output current (A) Bit05: Output power (kW) Bit06: Output torque (%) Bit07: S input status Bit08: MO1 output status Bit09: FIV/Voltage of potentiometer on operation panel (V) Bit10: FIC Voltage (V) Bit11: Reserved Bit12: Count value Bit13: Length value Bit14: Load speed display Bit15: PID setting	1F	☆

## Operation Instruction of AT20 Series Inverter

Function code	Parameter Name	Setting range	Default	Property
P7.04	LED display running parameter 2	0000~FFFF Bit00: PID feedback Bit01: PLC stage Bit02: Pulse input frequency(kHz) Bit03: Running frequency 2 (Hz) Bit04: Remaining running time Bit05: FIV/Voltage of potentiometer on operation panel before correction (V) Bit06: FIC voltage before correction (V) Bit07: Reserved Bit08: Motor rotational speed Bit09: Current power-on time(Hour) Bit10: Current running time (Min) Bit11: Pulse input frequency(Hz) Bit12: Communication setting value Bit13: Speed feedback of Encoder(Hz) Bit14: Main frequency X display(Hz) Bit15:Auxiliary frequency Y display (Hz)	0	☆

## Chapter 5 List of Function Parameters

Function code	Parameter Name	Setting range	Default	Property
P7.05	LED display stop parameter	0000~FFFF Bit00: Set frequency (Hz) Bit01: Bus voltage (V) Bit02: S input status Bit03: MO1 output status Bit04: FIV/Voltage of potentiometer on operation panel(V) Bit05: FIC voltage (V) Bit07: Count value Bit08: Length value Bit09: PLC stage Bit10: Load speed Bit11: PID setting Bit12: Pulse input frequency(kHz)	33	☆
P7.06	Load speed display coefficient	0.0001~6.5000	1.0000	☆
P7.07	Heatsink temperature of inverter IGBT	0.0°C ~120.0°C	-	●
<b>Group P8 Auxiliary Functions</b>				
P8.00	JOG running frequency	0.00Hz~maximum frequency	2.00Hz	☆
P8.01	JOG running frequency	0.0s~6500.0s	20.0s	☆
P8.02	JOG running frequency	0.0s~6500.0s	20.0s	☆
P8.03	JOG running frequency	0.00s~65000s	Model dependent	☆
P8.04	JOG running frequency	0.0s~65000s	Model dependent	☆
P8.05	JOG running frequency	0.0s~65000s	Model dependent	☆
P8.06	JOG running frequency	0.0s~65000s	Model dependent	☆
P8.07	JOG running frequency	0.0s~65000s	Model dependent	☆
P8.08	deceleration time 4	0.0s~65000s	Model dependent	☆
P8.09	Jump frequency 1	0.00Hz~maximum frequency	0.00Hz	☆
P8.10	Jump frequency 2	0.00Hz~maximum frequency	0.00Hz	☆

## Operation Instruction of AT20 Series Inverter

Function code	Parameter Name	Setting range	Default	Property
P8.11	Frequency jump amplitude	0.00Hz~maximum frequency	0.00Hz	☆
P8.12	Forward/Reverse rotation dead-zone time	0.0s~3000.0s	0.0s	☆
P8.13	Reverse control	0: Enabled 1: Disabled	0	☆
P8.14	Running mode when set frequency lower than frequency lower limit	0: Run at frequency lower limit 1: Stop 2: Run at zero speed	0	☆
P8.15	Droop control	0.00Hz~10.00Hz	0.00Hz	☆
P8.16	Accumulative power-on time threshold setting	0h~65000h	0h	☆
P8.17	Accumulative running time threshold setting	0h~65000h	0h	☆
P8.18	Startup protection	0: No protect 1: Protect	0	☆
P8.19	Frequency detection value (FDT1)	0.00Hz~maximum frequency	50.00Hz	☆
P8.20	Frequency detection hysteresis (FDT1)	0.0%~100.0% (FDT1 level)	5.0%	☆
P8.21	Detection range of frequency reached	0.0%~100.0% (maximum frequency)	0.0%	☆
P8.22	Jump frequency during the process of acceleration/ deceleration	0: Disabled 1: Enabled	0	☆
P8.25	Frequency switchover point between acceleration time 1 and acceleration time 2	0.00Hz~maximum frequency	0.00Hz	☆



## Chapter 5 List of Function Parameters

Function code	Parameter Name	Setting range	Default	Property
P8.26	Frequency switchover point between deceleration time 1 and deceleration time 2	0.00Hz~maximum frequency	0.00Hz	☆
P8.27	Terminal JOG preferred	0: Disabled 1: Enabled	0	☆
P8.28	Frequency detection value (FDT2)	0.00Hz~maximum frequency	50.00Hz	☆
P8.29	Frequency detection hysteresis (FDT2)	0.0%~100.0% (FDT2 level)	5.0%	☆
P8.30	Any frequency reaching detection value 1	0.00Hz~maximum frequency	50.00Hz	☆
P8.31	Any frequency reaching detection amplitude 1	0.0%~100.0% (maximum frequency)	0.0%	☆
P8.32	Any frequency reaching detection value 2	0.00Hz~maximum frequency	50.00Hz	☆
P8.33	Any frequency reaching detection amplitude 2	0.0%~100.0% (maximum frequency)	0.0%	☆
P8.34	Zero current detection level	0.0%~300.0% 100.0% corresponding to rated motor current	5.0%	☆
P8.35	Zero current detection delay time	0.01s~600.00s	0.10s	☆
P8.36	Output over-current threshold	0.0% (no detection) 0.1%~300.0% (rated motor current)	200.0%	☆
P8.37	Output over-current detection delay time	0.00s~600.00s	0.00s	☆
P8.38	Any current reaching 1	0.0%~300.0% (rated motor current)	100.0%	☆

## Operation Instruction of AT20 Series Inverter

Function code	Parameter Name	Setting range	Default	Property
P8.39	Any current reaching 1 amplitude	0.0%~300.0% (rated motor current)	0.0%	☆
P8.40	Any current reaching 2	0.0%~300.0% (rated motor current)	100.0%	☆
P8.41	Any current reaching 2 amplitude	0.0%~300.0% (rated motor current)	0.0%	☆
P8.42	Timing function selection	0:Disabled 1:Enabled	0	☆
P8.43	Timing duration source	0: P8.44 1: FIV/potentiometer on operation panel 2: FIC 3: Reserved 100% of analog input corresponds to the value of P8.44	0	☆
P8.44	Timing duration	0.0Min~6500.0Min	0.0Min	☆
P8.45	FIV input voltage lower limit protection value	0.00V~P8.46	3.10V	☆
P8.46	FIV input voltage upper limit protection value	P8.45~10.00V	6.80V	☆
P8.47	Module temperature threshold	0°C ~100°C	75°C	☆
P8.48	Cooling fan control	0: Fan working during running 1: Fan working continuously	0	☆
P8.49	Wakeup frequency	Dormant frequency (P8.51)~maximum frequency (P0.10)	0.00Hz	☆
P8.50	Wakeup delay time	0.0s~6500.0s	0.0s	☆
P8.51	Dormant frequency	0.00Hz~wakeup frequency (P8.49)	0.00Hz	☆
P8.52	Dormant delay time	0.0s~6500.0s	0.0s	☆
P8.53	Current running time reached	0.0Min~6500.0Min	0.0Min	☆

## Chapter 5 List of Function Parameters

Function code	Parameter Name	Setting range	Default	Property
P8.54	Output power correction coefficient	0~200%	100%	☆
P8.55	Emergency deceleration time	0~6553.5s	Model dependent	☆
<b>Group P9: Fault and Protection</b>				
P9.00	Motor overload protection selection	0: Disabled 1: Enabled	1	☆
P9.01	Motor overload protection gain	0.20~10.00	1.00	☆
P9.02	Motor overload warning coefficient	50%~100%	80%	☆
P9.03	Over voltage stall gain	0~100	30	☆
P9.04	Protection voltage of over voltage stall	120%~150%	130%	☆
P9.07	Short-circuit to ground upon power on	0: Disabled 1: Enabled	1	☆
P9.09	Fault auto reset times	0~20	0	☆
P9.10	YO action selection during fault auto reset	0: No act 1: Act	0	☆
P9.11	Time interval of fault auto reset	0.1s~100.0s	1.0s	☆
P9.12	Input phase lost/contactors suction protection selection	Unit's digit: Input phase lost protection Ten's digit: contactors suction protection 0: disabled 1: enabled	00	☆
P9.13	Output phase loss protection selection	0: Disabled 1: Enabled Unit's digit: output phase loss protection Ten's digit: output phase loss protection before running	1	☆

## Operation Instruction of AT20 Series Inverter

Function code	Parameter Name	Setting range	Default	Property
P9.14	1st fault type	0: No fault 1: Reserved 2: Over-current during acceleration 3: Over-current during deceleration 4: Over-current at constant speed 5: Over-voltage during acceleration 6: Over-voltage during deceleration 7: Over-voltage at constant speed 8: Over-load of butter resistance 9: Under voltage 10: AC drive overload 11: Motor overload 12: Input Phase lost		●
P9.15	2nd fault type	13: Power output phase loss 14: Module overheat 15: External equipment fault 16: Communication fault 17: Contactor fault 18: Current detection fault 19: Motor auto-tuning fault 20: Encoder/PG card fault 21: Parameters read-write fault 22: AC drive hardware fault 23: Short circuit to ground 24: Reserved 25: Reserved 26: Running time reached 27: User-defined fault 1 28: User-defined fault 2 29: Power-on time reached 30: Load becoming 0 31: PID feedback lost during running 40: Fast limit overtime	-	●

## Chapter 5 List of Function Parameters

Function code	Parameter Name	Setting range	Default	Property
P9.16	3rd (latest) fault type	41: Switchover motor when running 42: Speed deviation too large 43: Motor over speed 45: Motor over temperature 51: Initial position fault	-	●
<b>Group PA PID function</b>				
PA.00	PID setting source	0: PA.01 1: FIV/potentiometer on operation panel 2: FIC 3: Reserved 4: PULSE (S3, above 3.7KW) 5: Communication setting 6: Multi-reference	0	☆
PA.01	PID digit setting	0.0%~100.0%	50.0%	☆
PA.02	PID feedback source	0: FIV/potentiometer on operation panel 1: FIC 2: Reserved 3: FIV-FIC/ potentiometer on operation panel-FIC 4: PULSE (S3, above 3.7KW) 5: Communication setting 6: FIV+FIC/ potentiometer on operation panel +FIC 7: MAX ( FIV ,  FIC )/ MAX (  potentiometer on operation panel  ,  FIC ) 8: MIN ( FIV ,  FIC )/ MIN (  potentiometer on operation panel  ,  FIC )	0	☆
PA.03	PID action direction	0: Forward action 1: Reverse action	0	☆
PA.04	PID setting feedback range	0~65535	1000	☆
PA.05	Proportional gain Kp1	0.0~100.0	20.0	☆
PA.06	Integral time Ti1	0.01s~10.00s	2.00s	☆

## Operation Instruction of AT20 Series Inverter

Function code	Parameter Name	Setting range	Default	Property
PA.07	Differential time Td1	0.000s~10.000s	0.000s	☆
PA.08	Cut-off frequency of PID reverse rotation	0.00~maximum frequency	2.00Hz	☆
PA.09	PID deviation limit	0.0%~100.0%	0.0%	☆
PA.10	PID differential limit	0.00%~100.00%	0.10%	☆
PA.11	PID setting change time	0.00~650.00s	0.00s	☆
PA.12	PID feedback filter time	0.00~60.00s	0.00s	☆
PA.13	PID output filter time	0.00~60.00s	0.00s	☆
PA.14	Reserved	-	-	☆
PA.15	Proportional gain KP1	0.0~100.0	20.0	☆
PA.16	Integral time Ti2	0.01s~10.00s	2.00s	☆
PA.17	Differential time Td2	0.000s~10.000s	0.000s	☆
PA.18	PID parameter switchover condition	0: No switchover 1: Switchover via S terminal 2: Automatic switchover based on deviation 3: Automatic switchover based on running frequency	0	☆
PA.19	PID parameter switchover deviation 1	0.0%~PA.20	20.0%	☆
PA.20	PID parameter switchover deviation 2	PA.19~100.0%	80.0%	☆
PA.21	PID initial value	0.0%~100.0%	0.0%	☆
PA.22	PID initial value holding time	0.00~650.00s	0.00s	☆

## Chapter 5 List of Function Parameters

Function code	Parameter Name	Setting range	Default	Property
PA.25	PID integral property	Unit's digit: Integral separated 0: Invalid 1: Valid Ten's digit: Whether to stop integral operation when the output reaches 0: Continue integral operation 1: Stop integral operation	00	☆
PA.26	Detection value of PID feedback loss	0.0%: Not judging feedback loss 0.1%~100.0%	0.0%	☆
PA.27	Detection time of PID feedback loss	0.0s~20.0s	0.0s	☆
PA.28	PID operation at stop	0: No PID operation at stop 1: PID operation at stop	0	☆
<b>Group Pb: Swing Frequency, Fixed Length and Count</b>				
Pb.00	Swing frequency setting mode	0: Relative to the central frequency 1: Relative to the maximum frequency	0	☆
Pb.01	Swing frequency amplitude	0.0%~100.0%	0.0%	☆
Pb.02	Jump frequency amplitude	0.0%~50.0%	0.0%	☆
Pb.03	Swing frequency cycle	0.1s~3000.0s	10.0s	☆
Pb.04	Triangular wave rising time coefficient	0.1%~100.0%	50.0%	☆
Pb.05	Set length	0m~65535m	1000m	☆
Pb.06	Actual length	0m~65535m	0m	☆
Pb.07	Number of pulses per meter	0.1~6553.5	100.0	☆
Pb.08	Set count value	1~65535	1000	☆
Pb.09	Designated count value	1~65535	1000	☆
<b>Group PC Multi-Reference and Simple PLC Function</b>				
PC.00	Multi-Reference 0	-100.0%~100.0%	0.0%	☆

## Operation Instruction of AT20 Series Inverter

Function code	Parameter Name	Setting range	Default	Property
PC.01	Multi-Reference 1	-100.0%~100.0%	0.0%	☆
PC.02	Multi-Reference 2	-100.0%~100.0%	0.0%	☆
PC.03	Multi-Reference 3	-100.0%~100.0%	0.0%	☆
PC.04	Multi-Reference 4	-100.0%~100.0%	0.0%	☆
PC.05	Multi-Reference 5	-100.0%~100.0%	0.0%	☆
PC.06	Multi-Reference 6	-100.0%~100.0%	0.0%	☆
PC.07	Multi-Reference 7	-100.0%~100.0%	0.0%	☆
PC.08	Multi-Reference 8	-100.0%~100.0%	0.0%	☆
PC.09	Multi-Reference 9	-100.0%~100.0%	0.0%	☆
PC.10	Multi-Reference 10	-100.0%~100.0%	0.0%	☆
PC.11	Multi-Reference 11	-100.0%~100.0%	0.0%	☆
PC.12	Multi-Reference 12	-100.0%~100.0%	0.0%	☆
PC.13	Multi-Reference 13	-100.0%~100.0%	0.0%	☆
PC.14	Multi-Reference 14	-100.0%~100.0%	0.0%	☆
PC.15	Multi-Reference 15	-100.0%~100.0%	0.0%	☆
PC.16	Simple PLC running mode	0: Stop after the AC drive runs one cycle 1: Keep final values after the AC drive runs one cycle 2: Repeat after the AC drive runs one cycle	0	☆



## Chapter 5 List of Function Parameters

Function code	Parameter Name	Setting range	Default	Property
PC.17	Simple PLC retentive selection	Unit's digit: Retentive upon power failure 0: No 1: Yes Ten's digit: Retentive upon stop 0: No 1: Yes	00	☆
PC.18	Running time of simple PLC reference 0	0.0s(h)~6500.0s(h)	0.0s(h)	☆
PC.19	Acceleration/ deceleration time of simple PLC reference 0	0~3	0	☆
PC.20	Running time of simple PLC reference 1	0.0s(h)~6500.0s(h)	0.0s(h)	☆
PC.21	Acceleration/ deceleration time of simple PLC reference 1	0~3	0	☆
PC.22	Running time of simple PLC reference 2	0.0s(h)~6500.0s(h)	0.0s(h)	☆
PC.23	Acceleration/ deceleration time of simple PLC reference 2	0~3	0	☆
PC.24	Running time of simple PLC reference 3	0.0s(h)~6500.0s(h)	0.0s(h)	☆
PC.25	Acceleration/ deceleration time of simple PLC reference 3	0~3	0	☆
PC.26	Running time of simple PLC reference 4	0.0s(h)~6500.0s(h)	0.0s(h)	☆
PC.27	Acceleration/ deceleration time of simple PLC reference 4	0~3	0	☆

## Operation Instruction of AT20 Series Inverter

Function code	Parameter Name	Setting range	Default	Property
PC.28	Running time of simple PLC reference 5	0.0s(h)~6500.0s(h)	0.0s(h)	☆
PC.29	Acceleration/ deceleration time of simple PLC reference 5	0~3	0	☆
PC.30	Running time of simple PLC reference 6	0.0s(h)~6500.0s(h)	0.0s(h)	☆
PC.31	Acceleration/ deceleration time of simple PLC reference 6	0~3	0	☆
PC.32	Running time of simple PLC reference 7	0.0s(h)~6500.0s(h)	0.0s(h)	☆
PC.33	Acceleration/ deceleration time of simple PLC reference 7	0~3	0	☆
PC.34	Running time of simple PLC reference 8	0.0s(h)~6500.0s(h)	0.0s(h)	☆
PC.35	Acceleration/ deceleration time of simple PLC reference 8	0~3	0	☆
PC.36	Running time of simple PLC reference 9	0.0s(h)~6500.0s(h)	0.0s(h)	☆
PC.37	Acceleration/ deceleration time of simple PLC reference 9	0~3	0	☆
PC.38	Running time of simple PLC reference 10	0.0s(h)~6500.0s(h)	0.0s(h)	☆
PC.39	Acceleration/ deceleration time of simple PLC reference 10	0~3	0	☆

## Chapter 5 List of Function Parameters

Function code	Parameter Name	Setting range	Default	Property
PC.40	Running time of simple PLC reference 11	0.0s(h)~6500.0s(h)	0.0s(h)	☆
PC.41	Acceleration/ deceleration time of simple PLC reference 11	0~3	0	☆
PC.42	Running time of simple PLC reference 12	0.0s(h)~6500.0s(h)	0.0s(h)	☆
PC.43	Acceleration/ deceleration time of simple PLC reference 12	0~3	0	☆
PC.44	Running time of simple PLC reference 13	0.0s(h)~6500.0s(h)	0.0s(h)	☆
PC.45	Acceleration/ deceleration time of simple PLC reference 13	0~3	0	☆
PC.46	Running time of simple PLC reference 14	0.0s(h)~6500.0s(h)	0.0s(h)	☆
PC.47	Acceleration/ deceleration time of simple PLC reference 14	0~3	0	☆
PC.48	Running time of simple PLC reference 15	0.0s(h)~6500.0s(h)	0.0s(h)	☆
PC.49	Acceleration/ deceleration time of simple PLC reference 15	0~3	0	☆
PC.50	Time unit of simple PLC running	0: s (second) 1: h (hour)	0	☆

## Operation Instruction of AT20 Series Inverter

Function code	Parameter Name	Setting range	Default	Property
PC.51	Reference 0 source	0: Set by PC.00 1: FIV/Potentiometer on operation panel 2: FIC 3: Reserved 4: PULSE 5: PID 6: Set by preset frequency (P0.08), UP/DOWN can be modified	0	☆
<b>Group PD: Communication Parameters</b>				
PD.00	Baud rate	Unit's digit: MODBUS 0: 300BPS 1: 600BPS 2: 1200BPS 3: 2400BPS 4: 4800BPS 5: 9600BPS 6: 19200BPS 7: 38400BPS 8: 57600BPS 9: 115200BPS Ten's digit: Reserved Hundred's digit: Reserved Thousand's digit: Reserved	0005	☆
PD.01	Data format	0: No check, <8-N-2> 1: Even parity check, <8-E-1> 2: Odd Parity check, <8-O-1> 3: 8-N-1	3	☆
PD.02	Local address	1~247	1	☆
PD.03	Response delay	0ms~20ms	2	☆
PD.04	Communication timeout	0.0 (Invalid), 0.1s~60.0s	0.0	☆
PD.05	Data transfer format selection	Unit's digit: MODBUS 0: Non-standard MODBUS protocol 1: Standard MODBUS protocol Ten's digit: Reserved	1	☆
PD.06	Communication reading current resolution	0: 0.01A 1: 0.1A	0	☆

## Chapter 5 List of Function Parameters

Function code	Parameter Name	Setting range	Default	Property
<b>Group PP: User-Defined Function Codes</b>				
PP.00	User password	0~65535	0	☆
PP.01	Parameter Initialization	0: No operation 01: Restore factory settings except motor parameters	0	★
<b>Group C0 Torque control parameter</b>				
C0.00	Speed/Torque control mode selection	0: Speed control 1: Torque control	0	★
C0.01	Torque setting source selection in torque control mode	0: Digital setting 1 (C0.03) 1: FIV/ Potentiometer on operation panel 2: FIC 3: Reserved 4: PULSE 5: Communication setting 6: MIN (FIV,FIC)/ MIN (Potentiometer on operation panel,FIC) 7: MAX (FIV,FIC)/ MAX (Potentiometer on operation panel,FIC) (The full range of 1-7 corresponding to the digit setting of C0.03)	0	★
C0.03	Torque digit setting in torque control	-200.0%~200.0%	150.0%	☆
C0.05	Forward maximum frequency in torque control	0.00Hz~maximum frequency	50.00Hz	☆
C0.06	Reverse maximum frequency in torque control	0.00Hz~maximum frequency	50.00Hz	☆
C0.07	Acceleration time in torque control	0.00s~65000s	0.00s	☆
C0.08	Deceleration time in torque control	0.00s~65000s	0.00s	☆
<b>Group C5 Control optimization parameters</b>				

## Operation Instruction of AT20 Series Inverter

Function code	Parameter Name	Setting range	Default	Property
C5.00	DPWM switchover frequency upper limit	5.00Hz~maximum frequency	8.00Hz	☆
C5.01	PWM modulation mode	0: Asynchronous modulation 1: Synchronous modulation	0	☆
C5.02	Dead zone compensation mode selection	0: No compensation 1: Compensation mode 1	1	☆
C5.03	Random PWM depth	0: Random PWM invalid 1~10: PWM carrier frequency random depth	0	☆
C5.04	Rapid current limit	0: Disabled 1: Enabled	1	☆
C5.05	Voltage over modulation coefficient	100~110	105	☆
C5.06	Under voltage threshold setting	210~420	350	☆
C5.08	Dead zone time adjustment	100%~200%	150%	☆
C5.09	Over voltage threshold setting	200.0V~2500.0V	Model dependent	
<b>Group C6: FI Curve Setting(FI is FIV or FIC)</b>				
C6.00	FI curve 4 minimum input	0.00V~C6.02	0.00V	☆
C6.01	Corresponding setting of FI curve 4 minimum input	-100.0%~+100.0%	0.0%	☆
C6.02	FI curve 4 inflexion 1 input	C6.00~C6.04	3.00V	☆
C6.03	Corresponding setting of FI curve 4 inflexion 1 input	-100.0%~+100.0%	30.0%	☆
C6.04	FI curve 4 inflexion 2 input	C6.02~C6.06	6.00V	☆
C6.05	Corresponding setting of FI curve 4 inflexion 2 input	-100.0%~+100.0%	60.0%	☆

## Chapter 5 List of Function Parameters

Function code	Parameter Name	Setting range	Default	Property
C6.06	FI curve 4 maximum input	C6.06~+10.00V	10.00V	☆
C6.07	Corresponding setting of FI curve 4 maximum input	-100.0%~+100.0%	100.0%	☆
C6.08	FI curve 5 minimum input	0.00V~C6.10	0.00V	☆
C6.09	Corresponding setting of FI curve 5 minimum input	-100.0%~+100.0%	0.0%	☆
C6.10	FI curve 5 inflexion 1 input	C6.08~C6.12	3.00V	☆
C6.11	Corresponding setting of FI curve 5 inflexion 1 input	-100.0%~+100.0%	30.0%	☆
C6.12	FI curve 5 inflexion 2 input	C6.10~C6.14	6.00V	☆
C6.13	Corresponding setting of FI curve 5 inflexion 2 input	-100.0%~+100.0%	60.0%	☆
C6.14	FI curve 5 maximum input	C6.12~+10.00V	10.00V	☆
C6.15	Corresponding setting of FI curve	-100.0%~+100.0%	100.0%	☆
C6.16	Jump point of FIV	-100.0%~100.0%	0.0%	☆
C6.17	Jump amplitude of FIV input	0.0%~100.0%	0.5%	☆
C6.18	Jump point of FIC input	-100.0%~100.0%	0.0%	☆
C6.19	Jump amplitude of FIC input	0.0%~100.0%	0.5%	☆

### Monitoring parameters:

Function Code	Parameter Name	Unit
<b>Group D0 Basic monitoring parameters</b>		
D0.00	Running frequency (Hz)	0.01Hz
D0.01	Set frequency (Hz)	0.01Hz

## Operation Instruction of AT20 Series Inverter

Function Code	Parameter Name	Unit
D0.02	Bus voltage (V)	0.1V
D0.03	Output voltage (V)	1V
D0.04	Output current (A)	0.01A
D0.05	Output power (kW)	0.1kW
D0.06	Output torque (%)	0.1%
D0.07	S input status	1
D0.08	MO1 output status	1
D0.09	Potentiometer on operation panel/FIV Voltage (V)	0.01V
D0.10	FIC Voltage (V)	0.01V
D0.11	Reserved	
D0.12	Count value	1
D0.13	Length value	1
D0.14	Load speed display	1
D0.15	PID setting	1
D0.16	PID feedback	1
D0.17	PLC stage	1
D0.18	PULSE input pulse frequency (kHz)	0.01kHz
D0.19	Reserved	
D0.20	Remaining running time	0.1Min
D0.21	Potentiometer on operation panel /FIV voltage before correction	0.001V
D0.22	FIC voltage before correction	0.001V
D0.23	Reserved	
D0.24	Linear speed	1m/Min
D0.25	On the current power-on time	1Min
D0.26	The current running time	0.1Min
D0.27	Input pulse frequency	1Hz
D0.28	Communication setting value	0.01%
D0.29	Reserved	
D0.30	Reserved	
D0.31	Auxiliary frequency Y display	0.01Hz
D0.32	View any memory address values	1
D0.33	Reserved	
D0.34	Motor temperature value	1°C
D0.35	Target torque (%)	0.1%
D0.36	Reserved	1
D0.37	Power factor angle	0.1°
D0.38	Reserved	1
D0.39	Target voltage upon V/F separation	1V
D0.40	Output voltage upon V/F separation	1V



## Chapter 5 List of Function Parameters

---

Function Code	Parameter Name	Unit
D0.41	Reserved	
D0.42	Reserved	
D0.43	Reserved	
D0.44	Reserved	
D0.45	Fault info	0
D0.58	Z signal counter	1
D0.59	Set frequency (%)	0.01%
D0.60	Running frequency (%)	0.01%
D0.61	AC drive status	1
D0.74	AC drive output torque	0.1
D0.76	Accumulative power consumption low level	0.1°C
D0.77	Accumulative power consumption high level	1°C
D0.78	Linear speed	1m/min

**Fault code list:**

Fault code	Name	Fault code	Name
OC1	Over current during acceleration		
OC2	Over current during deceleration	IE	Current detection fault
OC3	Over current during constant speed	TE	Motor auto-tuning fault
OU1	Over voltage during acceleration		
OU2	Over voltage during deceleration	EEP	EEPROM read-write fault
OU3	Over voltage during constant speed	GND	Short circuit to ground fault
POF	Control power fault	END1	Accumulative running time reached fault
LU	Under voltage fault	END2	Accumulative power on time reached fault
OL2	AC drive over load	LOAD	Load becoming 0 fault
OL1	Motor over load	PIOE	PID feedback lost during running fault
LI	Input phase loss	CBC	Rapid current limit fault
LO	Output phase loss	ESP	Speed deviation too large fault
OH	Module over heat	OSP	Motor over speed fault
EF	External equipment fault		
CE	Communication fault		

# Appdenix 1

## ParameterDescription of PID Control(0.4~2.2kW V/F)

### 1. Main Functions of PID Control

Special function	Function description	Showing Code
Pressure setting and displaying	1) "Setting Pressure, Feedback Pressure" is displayed on the digital tube at the same time, unit is bar, and other contents can be switched to display. 2) Pressure mode can be adjusted by up and down keys. Refer to PA.00 parameter. PA.00 = 0: number target value PA.01	
PID Sleep Function	1) When the pressure arrives, the running frequency is less than the sleep frequency PA.29, and the duration is longer than the sleep time PA.30, the frequency drops to 0, and it enters the sleep mode, displaying "SLP". 2) The running frequency is higher than the sleep frequency PA.29, and when the frequency is under stable operation, the frequency inverter can recognize intelligently and enter the sleep mode. The related parameters PA.45~PA.48 3) Frequency bigger than PA.49, no judgment of sleep.	SLP
Wake-up function or leakage detection function of PID	In sleep, when the pressure drops to the set pressure of PA31, the frequency inverter wakes up and the PID starts to work.	
Anti freezing function	When sleep and anti-freezing function is effective, the duration is longer than PA.42, running PA.43 time at the frequency of PA.44.	
Detection of Pressure Sensor Wire Break	When the pressure sensor wire break, the frequency inverter will report the fault and display "PidE", refer to parameters PA26, PA27	PidE
High water pressure alarm	If the pressure is higher than PA.32, the high pressure fault will be reported and shutdown. The fault code (delayed time PA.35 then automatic reset failure after pressure returns to normal)	HP

## Operation Instruction of AT20 Series Inverter

Special function	Function description	Showing Code
Low water pressure alarm	If the pressure is lower than PA.33 and the duration is longer than PA.36, the low pressure fault will be reported and the shutdown. The fault code "LP" (Delay time PA.35 automatic reset fault)	LP
Water shortage alarm	"Detection frequency A"= 2 Hz below maximum frequency = P.10-2 Hz If the running frequency of frequency inverter is bigger than "detection frequency A", the duration is longer than PA. 37, and the pressure is less than PA. 34, the water shortage fault will be reported and shutdown.The fault code "LL"	LL
Automatic Reset Function for Water Shortage Fault	When water shortage fault occurs, the frequency inverter will automatically reset the fault and run. The automatic reset interval time refers to PA.39.PA.40. Realize the shutdown after cut off the water supply, and automatically restore the normal water supply after the tap water is normal.	

### 2. Controlled parameters of PID

Function Code	Parameter Name	Setting Range	Default	Property
<b>PA Group PID Function</b>				
PA.00	PID given source	0: PA.01 Setting 2: FIC 5: Communication giving 6: Multi-segment instruction giving	0	☆
PA.01	Setting pressure 0.00-50.00bar	0.00bar~PA.04 bar	2.50 bar	☆
PA.02	PID feedback source	1: FIC 5: Communication giving	1	☆
PA.03	PID action direction	0: forward action 1: reverse action	0	☆
PA.04	Pressure range 0.00-50.00bar	0~650.00 bar	10.00 bar	☆ 0.00-50.00bar
PA.05	Proportional gain Kpl	0.0~100.0	80.0	☆
PA.06	Integral time T1	0.01s~10.00s	2.00s	☆
PA.07	Derivative Time Td1	0.000s~10.000s	0.000s	☆

## Appdenix 1 ParameterDescription of PID Control

Function Code	Parameter Name	Setting Range	Default	Property
PA.08	reverse rotation cut-off frequency of PID	0.00~maximum frequency	0.00Hz	☆
PA.09	PID deviation limit	0.0%~100.0%	0.1%	☆
PA.10	PID Differential limiting	0.00%~100.00%	0.10%	☆
PA.11	PID giving change time	0.00~650.00s	0.00s	☆
PA.12	PID feedback filter time	0.00~60.00s	0.00s	☆
PA.13	PID output filter time	0.00~60.00s	0.00s	☆
PA.14	Reserved	-	-	☆
PA.15	Proportional gain Kp2	0.0~100.0	100.0	☆
PA.16	Integral time TI2	0.01s~10.00s	0.50s	☆
PA.17	Differential time Td2	0.000s~10.000s	0.000s	☆
PA.18	PID Parameter switchover condition	0: No switch over 1: Switch over via X terminal 2: Automatic switch over based on deviation	2	☆
PA.19	PID parameter switchover deviation 1	0.0%~PA.20	5.0%	☆
PA.20	PID parameter switchover deviation 2	PA.19~100.0%	10.0%	☆
PA.21	PID initial value	0.0%~100.0%	0.0%	☆
PA.22	PID initial value holding time	0.00~650.00s	0.00s	☆
PA.23	Forward direction maximum value of two output deviations	0.00%~100.00%	2.00%	☆
PA.24	Reverse direction maximum value of two output deviations	0.00%~100.00%	2.00%	☆

## Operation Instruction of AT20 Series Inverter

Function Code	Parameter Name	Setting Range	Default	Property
PA.25	PID integral property	Unit's digit: Integral separated 0: Invalid 1: Valid Ten's digit: Whether to stop integral operation when the output reaches 0: Continue integral operation 1: Stop integral operation	00	☆
PA.26	Detection value of PID feedback loss	0.00V: Not judging feedback loss Set 1.00V to be valid (2mA*500 ohms = 1.00V)	0.00V	☆
PA.27	Detection time of PID feedback loss	0.0s~20.0s	1.0s	☆
PA.28	PID operation at stop	0: No PID operation at stop 1: PID operation at stop	0	☆
PA.29	Sleep frequency	0.00~maximum frequency	25.00HZ	☆
PA.30	Sleep time	0.00~6000S	10S	☆
PA.31	Sleep wake-up percentage	0.0~ 100.0%	90.0%	☆
PA.32	Upper limit alarm value of feedback signal (e.g. high pressure)	PA.33~PA.04	5.00	☆
PA.33	Lower limit alarm value of feedback signal: set to 0, no alarm	0.00~PA.32	0	☆
PA.34	Detection value of water shortage pressure	0.00 ~ PA.01	0.25	☆
PA.35	When the pressure returns to normal and delays, PA.35 automatically relieves the high-voltage or low-voltage faults.	0~9999S	10S	☆

## Appdenix 1 ParameterDescription of PID Control

Function Code	Parameter Name	Setting Range	Default	Property
PA.36	Low voltage alarm detection time	0~9999S	10S	☆
PA.37	Water shortage alarm detection time	0~9999S	100S	☆
PA.38	Power-on automatic operation delay settings	0~65000S (0:0~65000S (0:Do not run automatically when power-on)	0	☆
PA.39	Interval time of 10 times ahead of automatic reset of water shortage	0~65000S	600S	☆
PA.40	Interval time of 10 times after reset of water-shortage pressure	0~1000 minutes	60 minutes	☆
PA.40	Interval time of 10 times after reset of water-shortage pressure	0~1000 minutes	60 minutes	☆
PA.41	Anti freezing valid: 1-Valid 0-Invalid	0~1	0	☆
PA.42	Anti freezing waiting time when sleep	0~65000s	900s	☆
PA.43	Anti freezing running time when sleep	0~65000s	30s	☆
PA.44	Anti freezing running frequency when sleep	0~50.00Hz	15.00 HZ	☆
PA.45	sleep judgment: only when Frequency change < P635/S, start to judging sleep	0~10.00Hz	0.50HZ	☆

## Operation Instruction of AT20 Series Inverter

Function Code	Parameter Name	Setting Range	Default	Property
PA.46	sleep judgment: Allowed declining pressure when frequency lower	0.0~10.0%	0.60%	☆
PA.47	sleep judgment: Declined frequency per second	0~10.00Hz	0.30HZ	☆
PA.48	Sleep judgment: times of frequency decline	0~1000	10□	☆
PA.49	Sleep judgment: frequency is higher than PA.49, no judgment of sleep	0~Maximum frequencyP0.10	42.00HZ	☆
PA.50	PID sample time	0~1000 ms	4ms	☆

### 3.Fault alarm

Fault name	Panel display	Fault code
Acceleration overcurrent	oC1	2
Deceleration overcurrent	oC2	3
Constant Speed overcurrent	oC3	4
Acceleration overvoltage	oU1	5
Deceleration overvoltage	oU2	6
Constant speed overcurrent	oU3	7
Buffer resistance overload (Continuous enter undervoltage)	POF	8
Undervoltage	LU	9
Frequency inverter overload	OL2	10
Motor overload	OL1	11
Module overheating	OH	14
External fault	EF	15
Communication overtime	CE	16



## Appdenix 1 ParameterDescription of PID Control

Fault name	Panel display	Fault code
Low water pressure alarm	LP	24
High water pressure alarm	hP	27
Water shortage alarm	LL	28
Run time arrival	End1	26
Power-on time arrival	End2	29
feedback loss at running time (Pressure sensor wire breaking detection)	PidE	31
Noted information	Operation panel display	
Frequency inverter under sleep	SLP	

## Appendix 2 Parameter Description of PID Control Vector Control

### 1. Controlled parameters of PID

Function Code	Parameter Name	Setting Range	Default	Property
PA Group PID Function				
PA.00	PID given source	0: PA.01 Setting	0	☆
PA.01	Setting pressure 0.00-50.00bar	0.00bar~PA.04 bar	2.50 bar	☆
PA.02	PID feedback source	1:FIC 5:Communication giving	1	☆
PA.03	PID action direction	0:forward action 1:reverse action	0	☆
PA.04	Pressure range 0.00-50.00bar	0~650.00 bar	10.00 bar	☆ 0.00- 50.00bar
PA.05	Proportional gain Kp1	0.0~100.0	80.0	☆
PA.06	Integral time Ti1	0.01s~10.00s	2.00s	☆
PA.07	Derivative Time Td1	0.00s~10.000s	0.000s	☆
PA.08	Reverse rotation cut-off frequency of PID	0.00~maximum frequency	0.00Hz	☆
PA.09	PID deviation limit	0.0%~100.0%	0.1%	☆
PA.10	PID differential limiting	0.00%~100.00%	0.10%	☆
PA.11	PID giving change time	0.00~650.00s	0.00s	☆
PA.12	PID feedback filter time	0.00~60.00s	0.00s	☆
PA.13	PID output filter time	0.00~60.00s	0.00s	☆
PA.14	Reserved			☆
PA.15	Proportional gain Kp2	0.0~100.0	100.0	☆
PA.16	Integral time Ti2	0.01s~10.0s	0.50s	☆
PA.17	Differential time Td2	0.000s~10.000s	0.000s	☆

## Appdenix 2 Parameter Description of PID Control Vector Control

Function Code	Parameter Name	Setting Range	Default	Property
PA.18	PID parameter switchover condition	0: No switch over 1: Switch over via X terminal 2: Automatic switch over based on deviation	2	☆
PA.19	PID parameter switchover deviation 1	0.0%~PA.20	5.0%	☆
PA.20	PID parameter switchover deviation 2	PA.19~100.0%	10.0%	☆
PA.21	PID initial value	0.0%~100.0%	0.0%	☆
PA.22	PID initial value holding time	0.00~650.00s	0.00s	☆
PA.23	Forward direction maximum value of two output deviations	0.00~100.00%	2.0%	☆
PA.24	Reverse direction maximum value of two output deviations	0.00~100.00%	2.0%	☆
PA.25	PID integral property	Unit's digit: Integral separated 0: Invalid 1: Valid Ten's digit: Whether to stop integral operation when the output reaches 0: Continue integral operation 1: Stop integral operation	00	☆
PA.26	Detection value of PID feedback loss	0.00V: Not judging feedback loss Set 1.00V to be valid (2mA*500 ohms = 1.00V)	0.00V	☆
PA.27	Detection time of PID feedback loss	0.0s~20.0s	1.0s	☆
PA.28	PID operation at stop	0: No PID operation at stop 1: PID operation at stop	0	☆

## Operation Instruction of AT20 Series Inverter

Function Code	Parameter Name	Setting Range	Default	Property
PA.29	Sleep frequency	0.00~maximum frequency	25.00Hz	☆

### 2. Fault alarm

Fault name	Panel display	Fault code
Acceleration overcurrent	oC1	2
Deceleration overcurrent	oC2	3
Constant Speed overcurrent	oC3	4
Acceleration overvoltage	oU1	5
Deceleration overvoltage	oU2	6
Constant speed overvoltage	oU3	7
Buffer resistance overload (Continuous enter undervoltage)	POF	8
Undervoltage	LU	9
Frequency inverter overload	OL2	10
Motor overload	OL1	11
Module overheating	OH	14
External fault	EF	15
Communication overtime	CE	16
Low water pressure alarm	LP	24
High water pressure alarm	hP	27
Water shortage alarm	LL	28
Run time arrival	End1	26
Power-on time arrival	End2	29
Feedback loss at running time (Pressure sensor wire breaking detection)	PidE	31
Noted information	Operation panel display	
Frequency inverter under sleep	SLP	

# Appdennix 3 Troubleshooting

## 1 Fault alarm and countermeasures

The drive has a number of warning messages and protection functions. Once the fault occurs, the protection function operates, the drive stops outputting, the drive fault relay contacts act, and the fault code is displayed on the drive display panel. Before seeking service, users can perform self-checking according to the tips in this section, analyze the cause of the fault, and find a solution. If it is the reason listed in the dotted box, please seek service, contact the agent of the drive you purchased or contact us directly.

The OUOC in the warning message is a hardware overcurrent or overvoltage signal. In most cases, the hardware overvoltage fault causes the OUOC alarm.

Fault Name	Display	Possible Causes	Solutions
servo drive unit protection	OC	1: The output circuit is grounded or short circuited. 2: The connecting cable of the motor is too long. 3: The module overheats. 4: The internal connections become loose. 5: The main control board is faulty. 6: The drive board is faulty. 7: The servo drive module is faulty	1: Eliminate external faults. 2: Install a reactor or an output filter. 3: Check the air filter and the cooling fan. 4: Connect all cables Properly. 5, 6, 7: Looking for technical support

## Operation Instruction of AT20 Series Inverter

Fault Name	Display	Possible Causes	Solutions
Overcurrent during acceleration	OC1	1: The output circuit is grounded or short circuited. 2: Motor auto-tuning is not Performed. 3: The acceleration time is too Short. 4: Manual torque boost or V/F curve is not appropriate. 5: The voltage is too low. 6: The startup operation is performed on the rotating motor. 7: A sudden load is added during Acceleration. 8: The AC drive model is of too small power class.	1: Eliminate external faults. 2: Perform the motor auto-tuning. 3: Increase the acceleration time. 4: Adjust the manual torque boost or V/F curve. 5: Adjust the voltage to normal range. 6: Select rotational speed tracking restart or start the motor after it stops. 7: Remove the added load. 8: Select an AC drive of higher power class.
Overcurrent during acceleration	OC2	1: The output circuit is grounded or short circuited. 2: Motor auto-tuning is not performed. 3: The deceleration time is too Short. 4: The voltage is too low. 5: A sudden load is added during Deceleration. 6: The braking unit and braking resistor are not installed.	1: Eliminate external faults. 2: Perform the motor auto-tuning. 3: Increase the deceleration time. 4: Adjust the voltage to normal range. 5: Remove the added load. 6: Install the braking unit and braking resistor.
Overcurrent at constant speed	OC3	1: The output circuit is grounded or short circuited. 2: Motor auto-tuning is not performed. 3: The voltage is too low. 4: A sudden load is added during operation. 5: The AC drive model is of too small power class.	1: Eliminate external faults. 2: Perform the motor auto-tuning. 3: Adjust the voltage to normal range. 4: Remove the added load. 5: Select an AC drive of higher power class.

Fault Name	Display	Possible Causes	Solutions
Overvoltage during acceleration	OU1	1: The input voltage is too high. 2: An external force drives the motor during acceleration. 3: The acceleration time is too Short. 4: The braking unit and braking resistor are not installed.	1: Adjust the voltage to normal range. 2: Cancel the external force or install a braking resistor. 3: Increase the acceleration time. 4: Install the braking unit and braking resistor.
Overvoltage during deceleration	OU2	1: The input voltage is too high. 2: An external force drives the motor during deceleration. 3: The deceleration time is too Short. 4: The braking unit and braking resistor are not installed.	1: Adjust the voltage to normal range. 2: Cancel the external force or install the braking resistor. 4: Install the braking unit and braking resistor.
Overvoltage at constant speed	OU3	1: The input voltage is too high. 2: An external force drives the motor during deceleration.	1: Adjust the voltage to normal range. 2: Cancel the external force or install the braking resistor.
Control power supply fault	POF	1: The input voltage is too high. 2: An external force drives the motor during deceleration.	1: Adjust the voltage to normal range. 2: Cancel the external force or install the braking resistor.
Undervoltage	LU	1: Instantaneous power failure occurs on the input power supply. 2: The AC drive's input voltage is not within the allowable range. 3: The bus voltage is abnormal. 4: The rectifier bridge and buffer resistor are faulty. 5: The drive board is faulty. 6: The main control board is faulty.	1: Reset the fault. 2: Adjust the voltage to normal range. 3, 4, 5, 6: Looking for technical support

## Operation Instruction of AT20 Series Inverter

Fault Name	Display	Possible Causes	Solutions
AC drive overload	OL2	<ol style="list-style-type: none"> <li>1: The load is too heavy or locked-rotor occurs on the motor.</li> <li>2: The AC drive model is of too small power class.</li> </ol>	<ol style="list-style-type: none"> <li>1: Reduce the load and check the motor and mechanical condition.</li> <li>2: Select an AC drive of higher power class</li> </ol>
Motor overload	OL1	<ol style="list-style-type: none"> <li>1: P9.01 is set improperly.</li> <li>2: The load is too heavy or locked- rotor occurs on the motor.</li> <li>3: The AC drive model is of too small power class.</li> </ol>	<ol style="list-style-type: none"> <li>1: Set P9.01 correctly.</li> <li>2: Reduce the load and check the motor and the mechanical condition.</li> <li>3: Select an AC drive of higher power class.</li> </ol>
Power input phase loss	LI	<ol style="list-style-type: none"> <li>1: The three-phase power input is abnormal.</li> <li>2: The drive board is faulty.</li> <li>3: The lightening board is faulty.</li> <li>4: The main control board is faulty.</li> </ol>	<ol style="list-style-type: none"> <li>1: Eliminate external faults.</li> <li>2, 3, 4: Looking for technical support</li> </ol>
Power output phase loss	Lo	<ol style="list-style-type: none"> <li>1: The cable connecting the AC drive and the motor is faulty.</li> <li>2: The AC drive's three-phase outputs are unbalanced when the motor is running.</li> <li>3: The drive board is faulty.</li> <li>4: The module is faulty.</li> </ol>	<ol style="list-style-type: none"> <li>1: Eliminate external faults.</li> <li>2: Check whether the motor three-phase winding is normal.</li> <li>3: Looking for technical support .</li> </ol>
Module overheat	OH	<ol style="list-style-type: none"> <li>1: The ambient temperature is too temperature.</li> <li>2: The air filter is blocked.</li> <li>3: The fan is damaged.</li> <li>4: The thermally sensitive resistor of the module is damaged.</li> <li>5: The servo drive module is damaged.</li> </ol>	<ol style="list-style-type: none"> <li>1: Lower the ambient High.</li> <li>2: Clean the air filter.</li> <li>3: Replace the damaged fan</li> <li>4: Replace the damaged thermally sensitive resistor.</li> <li>5: Replace the servo drive module.</li> </ol>
External equipment fault	EF	<ol style="list-style-type: none"> <li>1: External fault signal is input via X.</li> <li>2: External fault signal is input via virtual I/O.</li> </ol>	Reset the operation.



Fault Name	Display	Possible Causes	Solutions
Communication fault	CE	1: The host computer is in abnormal state. 2: The communication cable is faulty. 3: P028 is set improperly. 4: The communication parameters in group PD are set improperly.	1: Check the cabling of host computer. 2: Check the communication cabling. 3: Set P028 correctly. 4: Set the communication parameters properly.
Contactor fault	rAy	1: The drive board and power supply are faulty. 2: The contactor is faulty.	1: Replace the faulty drive board or power supply board. 2: Replace the faulty Contactor.
Current detection fault	IE	1: The HALL device is faulty. 2: The drive board is faulty.	1: Replace the faulty HALL device. 2: Replace the faulty drive board.
Motor auto-tuning fault	TE	1: The motor parameters are not set according to the nameplate. 2: The motor auto-tuning times out.	1: Set the motor parameters according to the nameplate property. 2: Check the cable connecting the AC drive and the motor.
Encoder fault	PG	1: The encoder type is incorrect. 2: The cable connection of the encoder is incorrect. 3: The encoder is damaged. 4: The PG card is faulty.	1: Set the encoder type correctly based on the actual situation. 2: Eliminate external faults. 3: Replace the damaged Encoder. 4: Replace the faulty PG card.
EEPROM read-write fault	EEP	The EEPROM chip is damaged.	Replace the main control board.
AC drive hardware fault	OJOC	1: Overvoltage exists. 2: Overcurrent exists.	1: Handle based on Overvoltage. 2: Handle based on overcurrent.
Short circuit to ground	GND	The motor is short circuited to the ground.	Replace the cable or motor.
Accumulative running time reached	END1	The accumulative running time reaches the setting value.	Clear the record through The parameter initialization function.

Fault Name	Display	Possible Causes	Solutions
Accumulative power-on time reached	END2	The accumulative power-on time reaches the setting value.	Clear the record through The parameter initialization function.
Load becoming 0	LOAD	The AC drive running current is lower than P9.64.	Check that the load is disconnected or the setting of P9.64 and P9.65 is correct.
PID feedback lost during running	PIDE	The PID feedback is lower than the setting of PA.26.	Check the PID feedback signal or set PA.26 to a proper value.
Pulse-by-pulse current limit fault	CBC	1: The load is too heavy or locked-rotor occurs on the motor. 2: The AC drive model is of too small power class.	1: Reduce the load and check the motor and mechanical condition. 2: Select an AC drive of higher power class.
Too large speed deviation	ESP	1: The encoder parameters are set incorrectly. 2: The motor auto-tuning is not Performed. 3: P9.69 and P9.70 are set incorrectly.	1: Set the encoder parameters properly. 2: Perform the motor auto-tuning. 3: Set P9.69 and P9.70 correctly based on the actual situation.
Motor over-speed	oSP	1: The encoder parameters are set incorrectly. 2: The motor auto-tuning is not Performed. 3: P9.69 and P9.70 are set incorrectly.	1: Set the encoder parameters properly. 2: Perform the motor auto-tuning. 3: Set P9.69 and P9.70 correctly based on the actual situation.
Initial position fault	ini	The motor parameters are not set based on the actual situation.	Check that the motor parameters are set correctly and whether the setting of rated current is too small.

## 2 Common Faults and Solutions

You may come across the following faults during the use of the AC drive. Refer to the following table for simple fault analysis.

Table 6-1 Troubleshooting to common faults of the AC drive

SN	Fault	Possible Causes	Solutions
1	There is no display at power-on.	1: There is no power supply to the AC drive or the power input to the AC drive is too low. 2: The power supply of the switch on the drive board of the AC drive is Faulty. 3: The rectifier bridge is damaged. 4: The control board or the operation panel is faulty. 5: The cable connecting the control board and the drive board and the operation panel breaks.	1: Check the power supply. 2: Check the bus voltage. 3: Looking for technical support
2	"9000" is displayed at power-on.	1: The cable between the drive board and the control board is in poor contact. 2: Related components on the control board are damaged. 3: The motor or the motor cable is short circuited to the ground. 4: The HALL device is faulty. 5: The power input to the AC drive is too low.	Looking for technical support
3	"GND" is displayed at power-on.	1: The motor or the motor output cable is short-circuited to the ground. 2: The AC drive is damaged.	1: Measure the insulation of the motor and the output cable with a megger. 2: Looking for technical support

## Operation Instruction of AT20 Series Inverter

SN	Fault	Possible Causes	Solutions
4	The AC drive display is normal upon power-on. But "9000" is displayed after running and stops immediately.	<ol style="list-style-type: none"> <li>1: The cooling fan is damaged or locked-rotor occurs.</li> <li>2: The external control terminal cable is short circuited.</li> </ol>	<ol style="list-style-type: none"> <li>1: Replace the damaged fan.</li> <li>2: Eliminate external fault.</li> </ol>
5	OH (module overheat) fault is reported frequently.	<ol style="list-style-type: none"> <li>1: The setting of carrier frequency is too high.</li> <li>2: The cooling fan is damaged, or the air filter is blocked.</li> <li>3: Components inside the AC drive are damaged (thermal coupler or others).</li> </ol>	<ol style="list-style-type: none"> <li>1: Reduce the carrier frequency (P017).</li> <li>2: Replace the fan and clean the air filter.</li> <li>3: Looking for technical support</li> </ol>
6	The motor does not rotate after the AC drive runs.	<ol style="list-style-type: none"> <li>1: Check the motor and the motor Cables.</li> <li>2: The AC drive parameters are set improperly (motor parameters).</li> <li>3: The cable between the drive board and the control board is in poor contact.</li> <li>4: The drive board is faulty.</li> </ol>	<ol style="list-style-type: none"> <li>1: Ensure the cable between the AC drive and the motor is normal.</li> <li>2: Replace the motor or clear mechanical faults.</li> <li>3: Check and re-set motor parameters.</li> </ol>
7	The S terminals are disabled.	<ol style="list-style-type: none"> <li>1: The parameters are set incorrectly.</li> <li>2: The external signal is incorrect</li> <li>3: The jumper bar across OP and +24 V becomes loose.</li> <li>4: The control board is faulty.</li> </ol>	<ol style="list-style-type: none"> <li>1: Check and reset the parameters in group P5.</li> <li>2: Re-connect the external signal cables.</li> <li>3: Re-confirm the jumper bar across OP and +24 V.</li> <li>4: Looking for technical support</li> </ol>
8	The motor speed is always low in CLVC mode.	<ol style="list-style-type: none"> <li>1: The encoder is faulty.</li> <li>2: The encoder cable is connected incorrectly or in poor contact.</li> <li>3: The PG card is faulty.</li> <li>4: The drive board is faulty.</li> </ol>	<ol style="list-style-type: none"> <li>1: Replace the encoder and ensure the cabling is proper.</li> <li>2: Replace the PG card.</li> <li>3: Looking for technical support</li> </ol>

SN	Fault	Possible Causes	Solutions
9	The AC drive reports overcurrent and overvoltage frequently.	1: The motor parameters are set improperly. 2: The acceleration/ deceleration time is improper. 3: The load fluctuates.	1: Re-set motor parameters or re-perform the motor auto-tuning. 2: Set proper acceleration/ deceleration time. 3: Looking for technical support
10	rAy is reported upon power-on or running.	The soft startup contactor is not picked up.	1: Check whether the contactor cable is loose. 2: Check whether the contactor is faulty. 3: Check whether 24 V power supply of the contactor is faulty. 4: Looking for technical support

## **Appendix 4**

# **Communication Protocol**

AT20 series inverter provides RS232 / RS485 communication interface, and support the Modbus communication protocol. Users can be achieved by computing machine or PLC central control, through the communication protocol set inverter running commands, modify or read function code parameters, read the inverter working condition and fault information, etc.

### **1, The agreement content**

The serial communication protocol defines the serial communication transmission of information content and format. Including: host polling or wide planting format; Host encoding method, the content includes: the function of the required action code, data transmission and error checking, etc. From the ring of machine should be used is the same structure, content including: action confirmation, return the data and error checking, etc. If there was an error in receiving information from a machine, or cannot achieve the requirements of the host, it will organize a fault feedback information in response to the host.

### **2, Application methods**

Application mode inverter with RS232 / RS485 bus access to the "from" single main PC/PLC control network.

### **3, Bus structure**

- (1) The interface way RS232 / RS485 interface hardware
- (2) Asynchronous serial transmission mode, half-duplex transmission mode. At the same time the host and the only one to send data from the machine and the other can only receive data. Data in the process of serial asynchronous communication, the form of a message, a frame of a frame to send
- (3) Topological structure from single host machine system. From the machine address set in the range of 1 ~ 247, 0 for broadcast communication address. In the network from the machine address must be unique.

## 4, Protocol Description

AT20 series inverter is a kind of asynchronous serial port communication protocol of master-slave Modbus communication protocol, the network has only one equipment (host) to establish agreement (called "query/command"). Other equipment (machine) can only by providing data response of the main machine "query/command", or "query/command" according to the host to make the corresponding action. Host in this refers to the personal computer (PC), industrial control equipment or programmable logic controller (PLC), etc., from machine refers to AT20 inverter. The host can communicate to a separate from the machine, also can to all under a broadcast information from machine release. For access to the host alone "query/command", from the machine to return to a information (called response), for radio host information, from the machine without feedback response to the host.

## 5, Communications data structure

Communication data structure AT20 series inverter of the Modbus protocol communication data format is as follows: using the RTU mode, messages are sent at least begin with 3.5 characters pause time interval.

In network wave rate under varied characters of the time, this is the most easy to implement (below T1, T2, T3, T4). Transmission equipment is the first domain address.

The transmission character of you can use is the hex 0...9, A...F. Continuously detect network bus network facilities, including pause interval of time. When the first domain (domain) to receive, every equipment decoding to determine whether to own. After the last transmission character, a pause at least 3.5 characters time calibration for the end of the message. A new message can be started after the pause.

The entire message frame must be as a continuous flow of transmission. If the time frame to complete more than 1.5 characters before pause time, receiving equipment will refresh incomplete message and assume that the next byte is a new message the address of the domain. Likewise, if a new message in less than 3.5 characters of time and then a message before, receiving equipment will think it is a continuation of the previous message. This will result in an error, because in the final CRC field value can't be right.

RTU frame format:

## Operation Instruction of AT20 Series Inverter

The frame header START	3.5 characters
Slave address ADR	Communication address: 1~247
command code CMD	03: Read the machine parameters; 06: write the machine parameters
Date content DATA (N-1 )	Information content: Function code parameter address, function code number of parameters, function code parameter values, etc
Data content DATA (N-2 )	
.....	
Data content DATA0	
high-order position of CRC CHK	estimated value: CRC value
low-order position of CRC CHK	
END	3.5 characters'time

CMD(Command instruction)and DATA(the description of data word) command code:03H,read N word(Word)(Can read the most words of 12)For example,From the machine address of 01 inverter startup F105 continuous read for two consecutive values

The host command information

ADR	01H
CMD	03H
high-order position of the starting address	F1H
low-order position of the starting address	05H
high-order position of register	00H
low-order position of register	02H
low-order position of CRC CHK	Wait to calculate the CRC CHK values
high-order position of CRC CHK	

In response to information from the slave machine

Set PD.05 to 0:

ADR	01H
CMD	03H
high-order position of bytes	00H
low-order position of bytes	04H
Data high-order position of F002H	00H
Data low-order position of F002H	00H
Data high-order position of F003H	00H
Data low-order position of F003H	01H
low-order position of CRC CHK	Wait to calculate the CRC CHK values
high-order position of CRC CHK	

Set PD.05 to 1:



ADR	01H
CMD	03H
The number of bytes	04H
Data high-order position of F002H	00H
Data low-order position of F002H	00H
Data high-order position of F003H	00H
Data low-order position of F003H	01H
low-order position of CRC CHK	Wait to calculate the CRC CHK values
high-order position of CRC CHK	

The command code:06H write a word(Word)For example,write 000(BB8H)to slave machine.

Address 05H inverter's F00AH address.

The host command information

ADR	05H
CMD	06H
high-order position of data address	F0H
low-order position of data address	0AH
high-order position of information content	0BH
low-order position of information content	B8H
low-order position of CRC CHK	Wait to calculate the CRC CHK values
high-order position of CRC CHK	

In response to information from the slave machine

ADR	02H
CMD	06H
high-order position of data address	F0H
low-order position of data address	0AH
high-order position of information content	13H
low-order position of information content	88H
low-order position of CRC CHK	Wait to calculate the CRC CHK values
high-order position of CRC CHK	

Check way—CRC Check way: CRC(Cyclical Redundancy Check) use RTU frame format, The message includes error detection field based on the method of CRC .CRC domain test the whole content of a message. CRC domain is two bytes, contains a 16-bit binary values. it is calculated by the transmission equipment, added to the message. receive messages the device recalculate. And compared with receives the CRC in the domain of value, if the two CRC value is not equal, then there is an error in transmission.

CRC is saved in 0xFFFF, Then call a process to continuous 8-bit bytes of the message and the values in the current register

for processing. Only 8 bit data in each character of CRC is effective, Starting bit and stopping bit and parity bits are invalid.

In the process of CRC, Each of the eight characters are separate and dissimilar or register contents(XOR), The results move to the least significant bit direction, set the most significant bit to 0. LSB is extracted to test, if set LSB to 1, Register and preset value dissimilarity or alone, if set LSB to 0, is not to. The whole process will repeat 8 times. when the last time ( the eighth time) is completed, next 8-bit bytes and separate and register under the current value of the alien or. The values in the final register, Is all bytes in the message is executed after the CRC value.

When CRC added to the messages .The low byte to join first and then high byte. CRC Simple function is as follows:

```
unsigned int crc_cal_value(unsigned char *data_value, unsigned
char data_length)
{
int i;
unsigned int crc_value=0xffff;
while(data_length-->0)
{
crc_value^=*data_value++;
for(i=0; i<8; i++)
{
if(crc_value&0x0001)
crc_value=(crc_value>>1)^0xa001;
else
crc_value=crc_value>>1;
}
}
Return(crc_value);
}
```

Address definition of communication parameters

This part is the content of the communication, used to control the operation of the inverter, inverter status and related parameters setting. Read and write functional code parameter (some function code which can not be changed, only for the use of manufacturers or monitoring) : function code parameter address label rules:

By function block number and the label for the parameter address representation rules .High byte: F0~FF(P group), A0~AF(C group), 70~7F(D group) low byte: 00~FF

Such as:P3.12,The address is expressed as F30C; attention: PF group:Neither read the parameters, and do not change parameters;Group D group: only can read, do not change the parameters.

When some parameters in inverter is in operation, do not change;Some parameters of the inverter in any state, cannot be changed;Change function code parameters, but also pay attention to the range of parameters, units, and related instructions.

In addition, because the EEPROM is stored frequently, the service life of the block can reduce the the life of the block EPROM, so some function code under the mode of communication, do not need to be stored, just change the value of RAM.If it is P group of parameters, in order to realize the function, as long as putting this function code address high F into 0 can be achieved.If it is C group of parameters, in order to realize the function, as long as putting the function code the address of high A into 4 can be achieved. Corresponding function codes are shown as the following address: the high byte: 00 ~ 0F (P group), 40 ~ 4F(group B) low byte: 00 to FF

Such as:

Function code P3.12 is not stored in the EEPROM,The address is expressed as 030C;Function code C0-05 is not stored in the EEPROM,The address is expressed as 4005; The address representation can only do writing RAM,can't do reading action,when reading,it is invalid address. For all the parameters, can also use the command code 7H to implement this function.

Stopping/starting parameters:

Parameter address	Parameter description
1000	Communication Setting value (-10000~10000 ) (decimal system )
1001	Operating frequency
1002	Bus voltage
1003	output voltage
1004	current output
1005	output power
1006	output torque
1007	running velocity
1008	S Input Flag
1009	M01 output Flag
100A	FIV voltage
100B	FIC voltage

100C	Reserved
100D	count value input
100E	The length of the input
100F	The load speed
1010	PID setting
1011	PID feedback
1012	PLC steps
1013	PULSE the input pulse frequency,unit 0.01kHz
1014	Reserved
1015	The remaining running time
1016	FIV before correction voltage
1017	FIC before correction voltage
1018	Reserved
1019	Linear velocity
101A	the current access to electricity time
101B	the current running time
101C	PULSE input pulse frequency,unit 1Hz
101D	Communication Setting value
101E	Reserved
101F	The main frequency X show
1020	Auxiliary frequency Y show

**attention:**

Communication setting value is relative percentage, 10000 corresponds to 100.00% and - 10000-100.00%.The frequency of dimensional data, the percentage is relative to the percentage of maximum frequency (P0.12);Counter rotating torque dimensional data, the percentage is P2.10.

Control command input to the inverter:(write-only)

The command word address	Command function
2000	0001:Running forward
	0002:Reverse running
	0003:normal inching turning
	0004:Reversal point move
	0005:Free downtime
	0006:Slowing down
	0007:Failure reset

Read the inverter state: (read-only)

Status word address	Status word function
---------------------	----------------------

3000	0001:Running forward
	0002:Reverse running
	0003:closing down

Parameters lock password check: (if return for 8888H,it indicates that the password check through)

Password address	The content of the input password
1F00	*****

Command address	Command content
2001	BIT0:(reserved) BIT1:(reserved) BIT2:RA-RB-RC output control BIT3:reserved BIT4:M01 output control

Analog output FOV control: (write-only)

Command address	Command content
2002	0~7FFF represent 0%~100%

Analog output control:(Reserved)

Command address	Command content
2003	0~7FFFrepresent 0%~100%

PULSE (PULSE) output control: (write -only)

Command address	Command content
2004	0~7FFFrepresent 0%~100%

Inverter fault description:

Inverter fault address	Inverter fault information
8000	0000:failure-free 0001:reserve 0002:Accelerate over current 0003:Slow down over current 0004:Constant speed over current 0005:Accelerate over the voltage 0006:Slow down over voltage 0007:Constant speed over voltage 0008:Buffer resistance overload fault 0009:Under-voltage fault 000A:The inverter overload 000B:Motor overload 000C:reserved 000D:The output phase 000E:Module is overheating 000F:External fault 0010:Abnormal communication

8000	0011:Abnormal contactor 0012:Current detection fault 0013:Motor tuning fault 0014:reserved 0015:Abnormal parameters, reading and writing 0016:Inverter hardware failure 0017:Motor for short circuit fault 0018:reserved 0019:reserved 001A:Running time reached 001B: reserved 001C: reserved 001D: Accumulative power-on time reached 001E:Load becoming 0 001F:PID feedback lost during running 0028:With-wave current limit fault 0029:Motor switchover fault during running 002A: Too large speed deviation 002B: Motor over-speed 002D:Motor overheat 005A:Encoder line number setting error 005B:Don't connect the encoder 005C:Initial position fault 005E:Speed feedback error
------	--

Communication failures address	Fault feature description
8001	0000:failure-free 0001:Password mistake 0002:The command code error 0003:CRC Checking error 0004:Invalid address 0005:Invalid parameter 0006:correcting parameter is invalid 0007:System is locked 0008:Block is EEPROM operation

PD group Communication parameters show

PD.00	Baud rate	The factory value	0005
PD.00	setting range	units' digit:MODUBS Baud rate 0:300BPS 1:600BPS 2:1200BPS 3:2400BPS 4:4800BPS 5:9600BPS 6:19200BPS 7:38400BPS 8:57600BPS 9:115200BPS	

This parameter is used to set data transfer rate between the PC

and inverter. Notice that setting the baud rate of upper machine and inverter must agree, otherwise, the communication can't carry on. The faster the baud rate, the greater the communication.

PD.01	The data format	The factory value	3
	setting range	0:No check:The data format<8,N,2> 1:Even-parity:The data format<8,E,1> 2:Odd parity check:The data format<8,O,1> 3:No check:The data format<8-N-1>	

PC and data format set by the inverter must agree, otherwise, the communication can't carry on.

PD.02	The machine address	The factory value	1
	setting range	1~247, 0 is the broadcast address	

When the machine address set to 0, namely for the broadcast address, realize PC broadcasting functions.

The machine address has uniqueness (except the broadcast address), which is to achieve the basis of upper machine and inverter peer-to-peer communications.

PD.03	Response latency	The factory value	2ms
	setting range	0~20ms	

Response latency: refers to the inverter data to accept the end up to a upper machine to send data in the middle of the interval of time. If the response time delay is less than the system processing time, the response time delay will be subject to system processing time, processing time, such as response time delay is longer than system after processing the data, the system will delay waiting, until the response delay time to up to a upper machine to send data.

PD.04	Communication timeout	The factory value	0
	setting range	0.0 s (invalid ) 0.1~60.0s	

When the function code is set to 0.0 s, communication timeout parameter is invalid.

When the function code set to valid values, if a communication and the interval time of the next communication beyond the communication timeout, system will be submitted to the communication failure error (CE). Usually, it is set into is invalid. If, in the continuous communication system parameter set the time, you can monitor the communication status.

PD.05	Communication protocol selection	The factory value	1
	setting range	0: Non standard Modbus protocol 1: The standard Modbus protocol	

PD.05=1:choose the standard Modbus protocol

PD.05=0: when reading command ,Returns number of bytes from the machine is a byte more than the standard Modbus protocol, detailed in this agreement

5 Communication data structures.

PD.06	Read the current resolution	The factory value	1
	setting range	0: 0.01A 1: 0.1A	

Used to determine the communication while reading the output current, current value of the output units.





**NIETZ ELECTRIC CO.,LTD**

**TEL:+86 21 33634649**

**[www.nietz.cn](http://www.nietz.cn)**

**E-mail: [info@nietz.cn](mailto:info@nietz.cn)**

The logo for NIETZ features the word "NIETZ" in a bold, blue, sans-serif font. The letter "I" is stylized with a red triangle at its base.

**Room 1506, XuHui Building ,No.168 YuDe Road Shanghai, China 200030**